

SP
23

Problem : #1

Area: Circuit I

Student Code _____

Referring to the circuit below, use source transformation method to arrive at the Thevenin voltage and resistance, between terminals a and b, first and then determine the value of R_L for maximize the power delivered to the entire load circuit. Evaluate the maximum power.

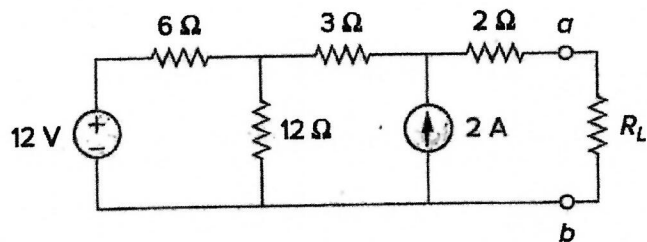

Problem : #2

Area Circuits/Electronics

Student Code _____

For the following circuit, answer parts a), b), c), d).

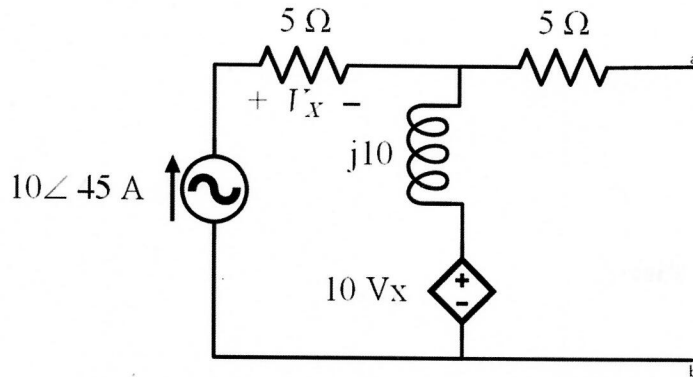

- Find the open circuit voltage, V_{OC} , or short circuit current, I_{SC} , at the terminals a-b.
- Using a $1 \angle 0$ dummy voltage source at the terminals a-b, find the Thevenin equivalent impedance Z_{Th} .
- Find the Norton Current, I_N , and the Thevenin Voltage, V_{Th} .
- Draw the equivalent Thevenin and Norton circuits.

Problem : 4

Area Electronics

Student Code _____

Consider the following low power Schottky (TTL) circuit. Assume that the schottky diode turn-on voltage is $V_{\gamma}(\text{SD}) = 0.3 \text{ V}$ and the transistor parameters are : $V_{\text{BE}}(\text{on}) = 0.7 \text{ V}$, $V_{\text{CE}}(\text{sat}) = 0.4 \text{ V}$ and $\beta = 25$. Calculate power dissipation for the low input, P_L and high input, P_H conditions.

Assume that for the low input condition, $v_X = v_Y = 0.4 \text{ V}$ and for high input condition, $v_X = v_Y = 3.6 \text{ V}$

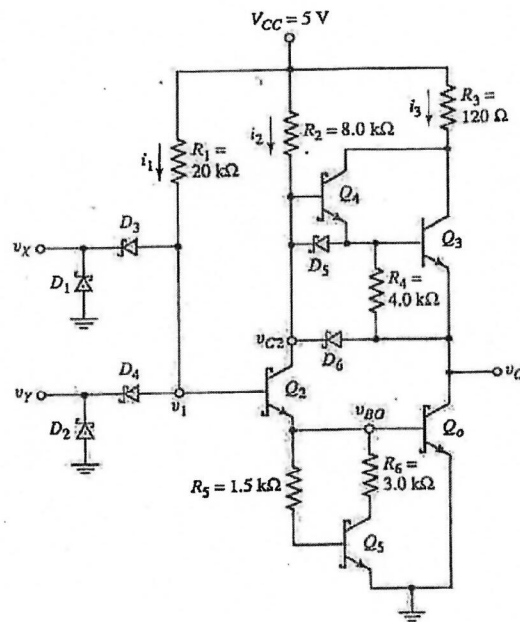

Refer to Fig. 1 for the system with ideal Continuous-to-Discrete (C-to-D) and Discrete-to-Continuous (D-to-C) converters.

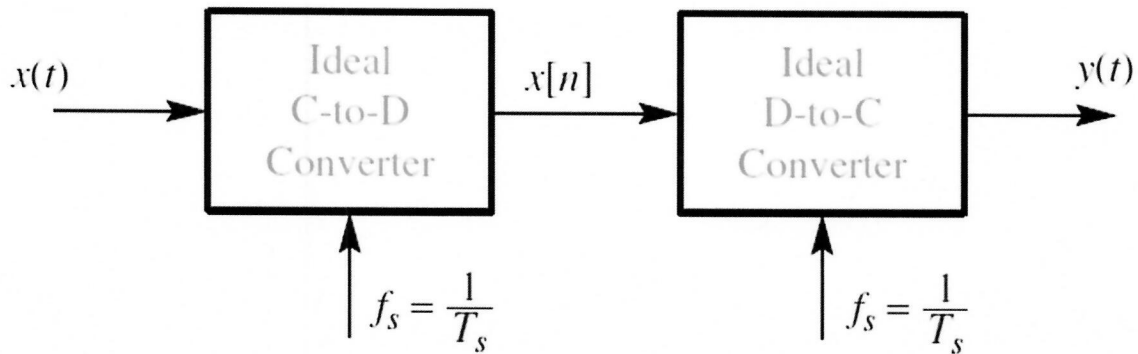

Figure 1: Ideal C-to-D and D-to-C system.

(a) Suppose that the output from the C-to-D converter is $x[n] = \cos(0.2\pi n)$, and the sampling rate of the C-to-D converter is $f_s = 8000$ samples/s. Determine a formula for the continuous-time sinusoidal input $x(t)$ using the smallest frequency greater than 10000 Hz.

(b) Suppose the output from the C-to-D converter is $x[n] = \cos(0.25\pi n)$, the input signal is $x(t) = \cos(510\pi t)$, and the sampling rate (f_s) of the C-to-D converter is less than 130 samples/s. Determine the largest possible sampling rate satisfying these three conditions.

Problem : P7

Area: Communications / Signal Processing

Student Code: _____

Let a be a random variable which is uniformly distributed on the interval $[0,2]$. Define two random variables X and Y as

$$X \triangleq \min \{a, 2 - a\},$$

$$Y \triangleq \max \{a, 2 - a\},$$

and let $Z \triangleq \frac{Y}{X}$.

- (1) Please derive the probability density function of X .
- (2) Please derive the probability density function of Z .
- (3) Please calculate the expectation of $\frac{X}{Y}$.

Problem: #13

Area: Power

Student Code: _____

In the following circuit, find the following (both amplitude and angle):

- I_1 , I_2 , and I_3 (45 points).
- $I_{A'C'}$ (Capacitor current) (15 points).
- Phase voltage of the load $(5+j10)$ equal to V_{un} (15 points).
- 3-phase complex power of the source (15 points)
- 3-phase complex power of the capacitor bank. (10 points)

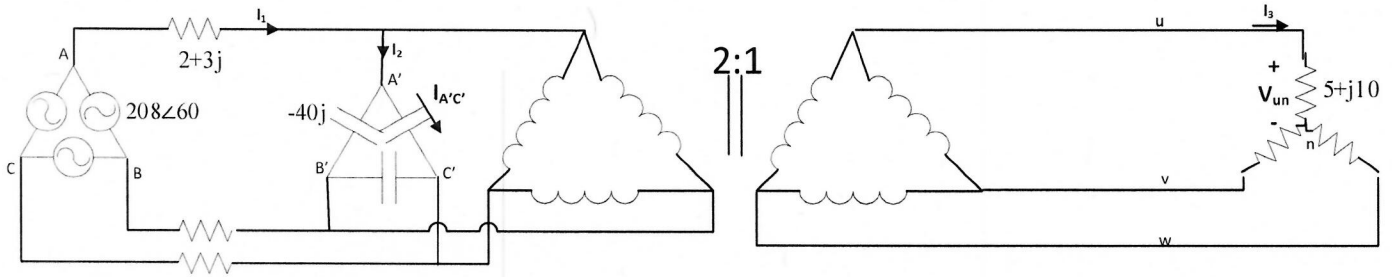

Problem: 15**Area: Power****Student Code: _____**

A Boost dc-dc converter has the following parameters: $V_{in} = 400$ V, $d = 0.25$, $V_{out} = 650$ V, $L = 100$ μ H, and $f_{sw} = 100$ kHz.

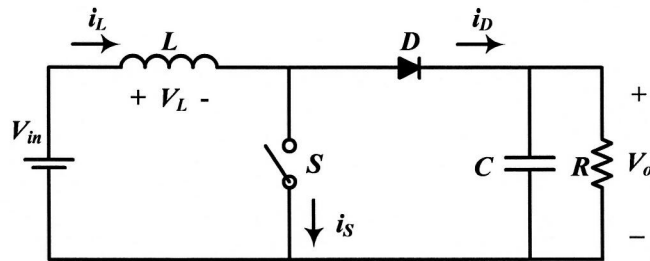

- Find the peak value of the inductor current.
- Accurately plot the waveform of the inductor current.
- Find the average value of the inductor current.
- Find the input power.
- Find the value of the load resistor.

Problem: 16

Area: Power

Student Code: _____

In the system shown below, a solid single line-ground fault occurs on bus 3. Both generators are solidly grounded.

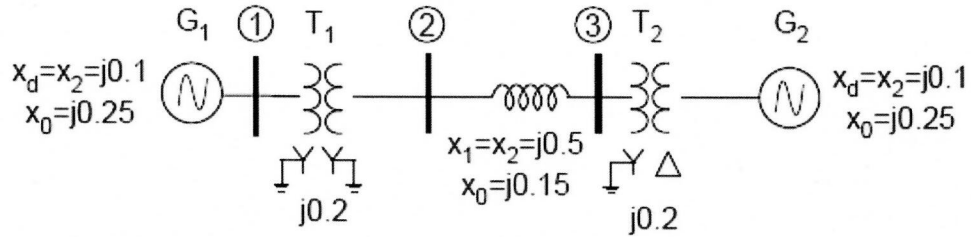

The prefault voltages are 1.0 per unit. What are the positive, negative and zero sequence fault currents in line 2-3 during the fault?

At 300 K, an asymmetric abrupt p-n junction's acceptor concentration (N_A) is $1.0 \times 10^{18} \text{ cm}^{-3}$ in the p-side and donor concentration (N_D) of $1.0 \times 10^{12} \text{ cm}^{-3}$ in the n-side. Calculate the equilibrium minority carrier concentrations in p-side and n-side:

p-side:

n-side:

Complete two plots of $\Delta p(x)$ and $\Delta n(x)$ profiles across this junction when $\Delta p(x=x_n) = 1.0 \times 10^{10} \text{ cm}^{-3}$ and $\Delta n(x=-x_p) = 1.0 \times 10^6 \text{ cm}^{-3}$ under forward bias.

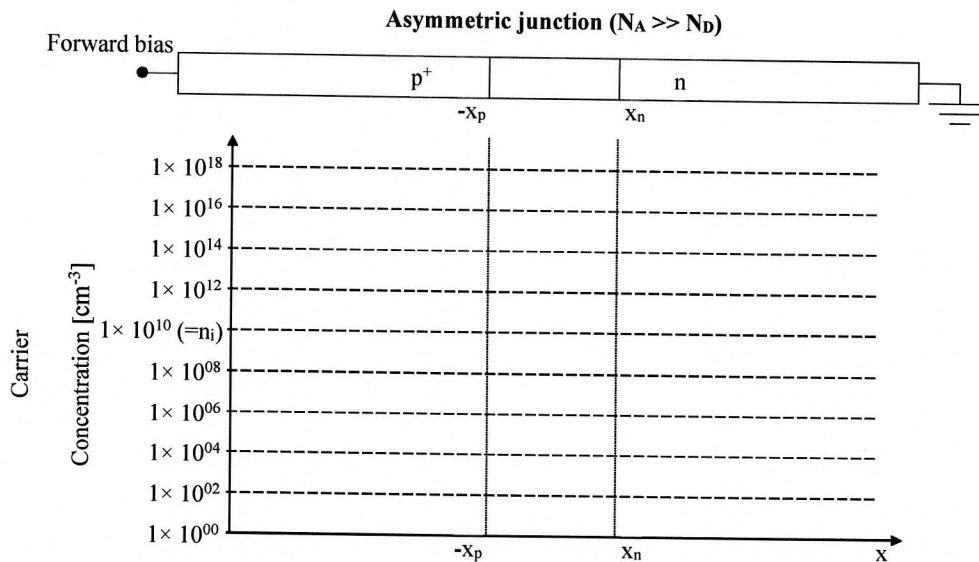

Constants*		Equations (p-n junction)*
$kT = 0.0259 \text{ [eV]}$	(at 300 K)	$F(E) = 1 / [1 + \exp((E - E_F) / kT)]$
Si Bandgap = 1.12 [eV]	(at 300 K)	$n_{no} (= n_{po}) = N_c \exp[-(E_c - E_F) / kT]$
Intrinsic carrier concentration of Si = $1 \times 10^{10} \text{ [cm}^{-3}]$	(at 300 K)	$p_{no} (= p_{po}) = N_v \exp[-(E_F - E_v) / kT]$
$N_c = 2.86 \times 10^{19} \text{ [cm}^{-3}]$	(at 300 K)	$n_o p_o = n_i^2$
$N_v = 2.66 \times 10^{19} \text{ [cm}^{-3}]$	(at 300 K)	$n_{no} (= n_{po}) = n_i \exp[(E_F - E_i) / kT]$
Elementary charge = $1.6 \times 10^{-19} \text{ [C]}$		$p_{no} (= p_{po}) = n_i \exp[(E_i - E_F) / kT]$
$\epsilon_o = 8.85 \times 10^{-14} \text{ [F/cm]}$		$n_{no} p_{no} = n_i^2$
$\epsilon_s = 11.9 \epsilon_o \text{ [F/cm]}$	(Si)	$n_{po} p_{po} = n_i^2$
$\epsilon_{ox} = 3.9 \epsilon_o \text{ [F/cm]}$	(SiO ₂)	$n_n = n_{no} + \Delta n, p_n = p_{no} + \Delta p \text{ } (\Delta n = \Delta p)$
		$n_p = n_{po} + \Delta n, p_p = p_{po} + \Delta p \text{ } (\Delta n = \Delta p)$

* Definition of parameters are not provided. It is expected that the examinee interprets the meaning.

Problem: 19

Area: Waves & Devices

Student Code: _____

Concentric spherical metal shell. The figure below shows a cross-section of a concentric spherical metal shell. The radii of the inner solid spherical conductor, the inner wall of the outer spherical conductor, and the outer wall of the outer spherical conductor are a , b , and c , respectively, as marked in the figure. Consider a positive surface charge density σ at the surface of the inner spherical conductor.

- A) Find the electric field everywhere as a function of radial distance r (i.e., $r < a$, $a < r < b$, $b < r < c$ and $r > c$).
- B) Please plot the electric field strength as a function of radial distance r .

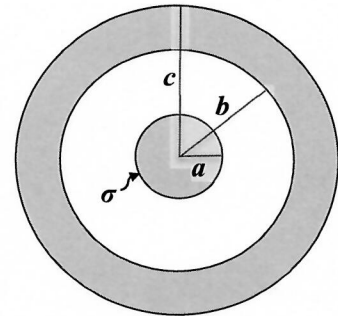

Problem : 20

Area: Waves & Devices

Student Code:_____

Air-perfect conductor interface. A uniform plane electromagnetic wave traveling in the air with its electric field given by $\overline{E}_i(x,t) = \hat{y}15 \cos(44 \times 10^9 t - \beta x)$ V/m is normally incident on a perfect conductor boundary located at $x = 0$. (a) Find the propagation constant β . (b) Find the corresponding magnetic field $\overline{H}_i(x,t)$. (c) Find the electric and magnetic fields $\overline{E}_r(x,t)$ and $\overline{H}_r(x,t)$ of the reflected wave. (d) Find the nearest two positions in the air away from the boundary where the total electric field is always zero.

Problem: # 21 Area: Computational Intelligence

Code # _____

Answer the questions for parts a and b below.

(a) Explain the validity that a given CI technique can be applied to any application that requires classification of a dataset into known classes. Provide examples where possible.

(b) Define the following terms:

(i) Data fusion

(ii) artificial intelligence

Problem: # 22 Area: Computational Intelligence

Code # _____

Answer the questions for parts a and b below.

(a) Describe different types of hardware evolution. Provide diagrams where possible.

(b) Define the following terms:

(i) Embryonics

(ii) Adaptive Devices, Circuits and Systems

(iii) Immunotronics

Problem: #23 Area: Computational Intelligence

Code # _____

Given the following feedforward neural network in Fig. Q2 with a sigmoid function (given below) in the hidden layer and a linear function in the output layer

$$d_1 = \frac{1}{1 + e^{-a_1}}$$

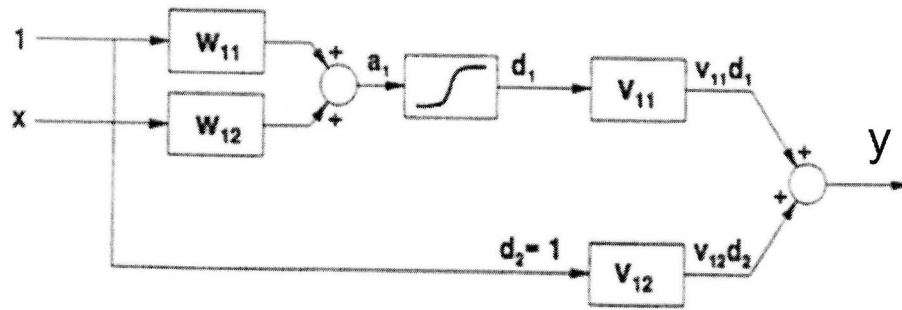

Fig. Q2

Given that $[W_{11}, W_{12}, V_{11}, V_{12}] = [1.0, 0.5, -1, 0.5]$, calculate the output y for $x = 0.5$.

Problem: #24 Area: Computational Intelligence

Code # _____

(a) Are neural networks, as currently used in engineering, based on models of the human brain? Explain the reasons for your answer in detail.

(b) In the context of computational intelligence algorithms, define the following terms: (i) Supervised learning. (ii) Unsupervised learning. (iii) Reinforcement learning.

Problem: P29

Area: Integrated Circuits and Logic Design

Code # _____

Answer the questions for parts **a** and **b** below.

- a. Simplify the logic expression $G(a,b,c) = (ab+\bar{c})(\bar{b}c+\bar{a})(\bar{a}+c)$ using any appropriate method to obtain the minimal sum-of-products (SOP) expression. Individual gates are not restricted on the number of inputs. *Show your work for full credit.*
- b. Draw the logic network (digital circuit) for the minimal SOP from part a. The logic gates are not restricted with the number of inputs.

Problem: P30

Area: Integrated Circuits and Logic Design

Code # _____

Answer the following questions.

a) Convert to binary:

9CD (hex) =

b) Convert to binary:

179.3125 (decimal) =

c) Convert to octal:

1110110110010.1110110 (binary) =

Problem: P30

Area: Integrated Circuits and Logic Design

Code # _____

d) Convert -61 to 8 bit 2's complement representation.

e) Perform the 2's complement multiplication 11001 x 11010

f) Perform the following two's complement addition operations. Give your answer as an 8-bit two's complement number. State whether overflow occurs.

1 1 1 0 1 1 1 0
+ 1 0 1 1 1 0 1 1

0 1 0 1 0 1 1 0
+ 0 0 1 1 0 0 1 1

Problem: P31

Area: Integrated Circuits and Logic Design

Code # _____

Design a 2-bit up counter with the state sequence specified as 01230123... using SR flip-flops, including drawing the counter circuit. Show your design steps for full credit.

Problem: P32

Area: Integrated Circuits and Logic Design

Code # _____

Draw a circuit to implement the function $g(w, x, y, z) = \sum m(1,3,4,5,8,9,10,11,13,15)$ using two 3-to-8 decoders with active low outputs and active high enables. You may use other logic gates as needed for the implementation of the decoder circuit.

w	x	Y	z	g
0	0	0	0	
0	0	0	1	
0	0	1	0	
0	0	1	1	
0	1	0	0	
0	1	0	1	
0	1	1	0	
0	1	1	1	
1	0	0	0	
1	0	0	1	
1	0	1	0	
1	0	1	1	
1	1	0	0	
1	1	0	1	
1	1	1	0	
1	1	1	1	

Problem: P33

Area: Networking, Security, and Dependability

Student Code: _____

This problem has two parts. For full credit, you must answer both parts correctly.

- a. Compare the UDP and TCP protocols in terms of each of the following attributes:
- bit overhead
 - processing overhead
 - reliability
 - flexibility in supporting different type of traffic, e.g, VoIP, file transfer, telemetry
- b. Compare the functions of a hub/repeater, switch, and router in computer networks. Explain which type of node is required when connecting ATM-based and Ethernet-based networks in the TCP/IP stack.

Problem: P34

Area: Networking, Security, and Dependability

Student Code: _____

This problem has two parts. For full credit, you must answer both parts correctly.

Answer the following questions for the network shown below:

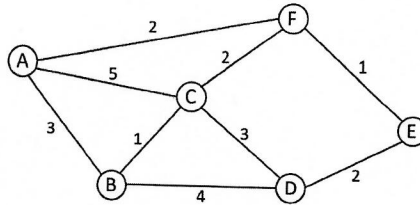

- a. Suppose each node runs the Distance Vector Routing Protocol. Complete the table below to show, step-by-step, how to find the shortest path from each node to destination node F. Each entry in columns A through E should be of the form (NextHop, Cost).

Iteration	A	B	C	D	E

- b. Suppose the link between nodes F and E is broken (removed) after the protocol converges in part a. Show step by step how the protocol continues until it converges again.

Iteration	A	B	C	D	E

This problem has two parts. For full credit, you must answer both parts correctly.

- a. Nodes A and B are attached to opposite ends of a 100 Mbps Ethernet cable segment. Suppose A begins transmitting a frame and before it finishes, B begins transmitting a frame. For A to detect collision with B, what should be the maximum length of the Ethernet cable segment? Assume that the transmit frame size is 500 bits and signal propagation speed is 2×10^8 m/sec. Show your work.

- b. The table below is a routing table using CIDR. Address bytes are in hexadecimal. Leading zeroes are dropped for each byte, e.g., 02 is written as 2. The notation "/12" in C4.50.0.0/12 denotes a mask with 12 leading 1 bits: FF.F0.0.0.

Prefix/Length	Next Hop
C4.50.0.0/12	A
C4.5E.10.0/20	B
C4.60.0.0/12	C
C4.68.0.0/14	D
80.0.0.0/1	E
40.0.0.0/2	F
3.0.0.0/2	G

Determine the next hop for a packet with each of the following destination addresses, assuming the match with the longest prefix is selected. Show your work.

- i. C4.6B.31.2E

- ii. 5E.43.91.12

