

Name \_\_\_\_\_  
Instructor \_\_\_\_\_  
Section/College \_\_\_\_\_

## **Electrical Engineering Advancement Exam III**

**SPRING SEMESTER 2021**

**CLOSED BOOK, CLOSED NOTES**  
**2 HOUR TIME LIMIT**

**CALCULATORS ARE ALLOWED**

(calculators without communication capability only)

**ELECTRONIC DEVICES WITH COMMUNICATION CAPABILITY**

(electronic devices such as cell phone, pagers, and iPads)

**MAY NOT BE USED DURING THE EXAMINATION**

(If such devices ring or are visible, a 10% penalty will be given for the first occurrence and exam failure for the second.)

There are 10 problems: please look over the exam to make sure that you have 10 different problems. **Do any eight (8) problems!** Draw a large X through the two problems that you do not want to be graded. If you do not indicate which problems you want to leave out, the first 8 problems will be graded.

Do all work for each problem only on the page supplied for that problem (you may use both sides). **DO NOT**, for instance, continue Problem #3 on the back of Problem #2. Extra blank paper will be supplied if needed. If extra paper is used, show the additional work for each problem on a separate sheet and staple the extra sheet(s) to the appropriate problems.

(1)

For parts a, b, and c, consider a GaAs semiconductor ( $n_i = 2.1 \times 10^6 \text{ cm}^{-3}$  at RT) doped with only one type of unknown dopant that results in the shown energy band diagram. Assume RT for the numerical analysis.

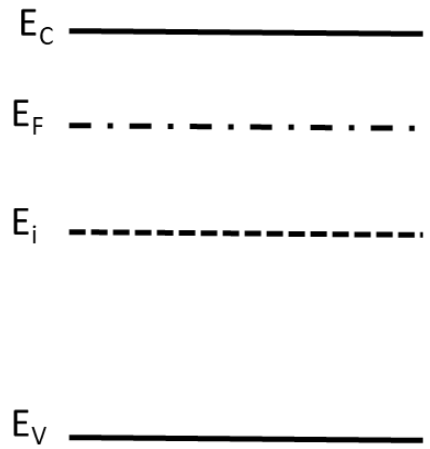

(a) [3 points] Is the semiconductor n-type or p-type? (Circle one)

**n-type**      **p-type**      **Answer: n-type**

(b) [4 points] Identify the types of dopants that could possibly create this semiconductor. (Circle all possible cases.)

**Ge**   **Si**   **P**   **N**   **In**   **A: Ge Si**

(c) [10 points] If  $E_C - E_F = 0.25 \text{ eV}$ , calculate the majority and minority concentration values. Go up to 7 decimal places for all answers.

**Answer:**

$$E_F - E_i = E_G/2 - (E_C - E_F) = 1.42/2 - 0.25 = 0.46 \text{ eV}$$

$$n_o = n_i \exp[(E_F - E_i)/kT] = (2.1 \times 10^6) \exp[0.46/0.0259] = 1.0853194 \times 10^{14} \text{ cm}^{-3}$$

$$p_o = n_i \exp[-(E_F - E_i)/kT] = (2.1 \times 10^6) \exp[-0.46/0.0259] = 0.0406332 \text{ cm}^{-3}$$

$p_o =$  \_\_\_\_\_       $n_o =$  \_\_\_\_\_

(d) [2 points] For an **intrinsic** semiconductor, sketch the variation of  $n_i$  vs.  $1/T$  where T is temperature.

(e) [6 points] For a doped semiconductor, sketch the variation of the majority carrier vs.  $1/T$  where T is temperature. Clearly label the intrinsic and extrinsic region.

(2)

Consider the energy band diagram of a biased Si PN junction shown. An external bias voltage  $V_A$  is applied per our convention. The RT intrinsic concentration of Si is  $1.50 \times 10^{10} \text{ cm}^{-3}$ .

$$E_{iP} - E_{FP} = 0.40 \text{ eV}$$

$$E_{FN} - E_{iN} = 0.20 \text{ eV}$$

Assuming room temperature.

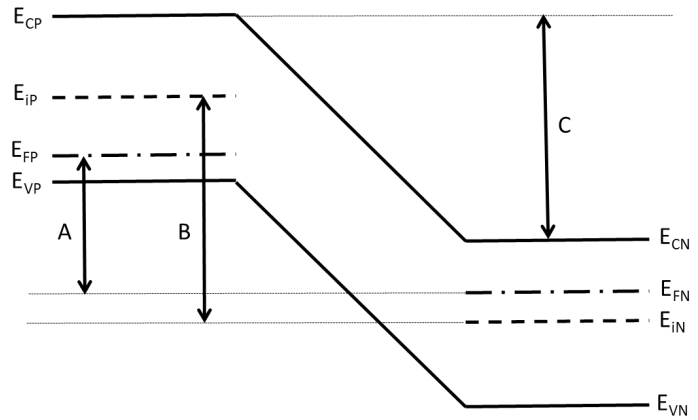

(a) [3 points] Is the junction reverse biased or forward biased? (Circle one)

*Reverse Biased*

*Forward Biased*

**Answer: Reverse Biased**

(b) [16 points] Calculate the values of the effective doping on each side of the junction, of the contact potential  $V_0$ , and of the external bias voltage  $V_A$  if the observed value of depletion width is  $9.0338 \mu\text{m}$ . Assume that the effective doping concentration, in each region, is equal to the majority carrier concentration in that region.

$$V_0 = (1/q)[(E_{FN} - E_i) - (E_{FP} - E_i)] = (1/q)[0.2 \text{ eV} - (-0.4 \text{ eV})] = 0.6 \text{ V}$$

$$N_{dn,eff}^+ = n_o = n_i \exp[(E_{FN} - E_i)/kT] = (1.5 \times 10^{10}) \exp[0.2/0.0259] = 3.3862312 \times 10^{13} \text{ cm}^{-3}$$

$$N_{ap,eff}^- = p_o = n_i \exp[-(E_{FP} - E_i)/kT] = (1.5 \times 10^{10}) \exp[-0.4/0.0259] = 7.6443744 \times 10^{16} \text{ cm}^{-3}$$

**W = (see equation sheet)**

$$V_A = -1.5 \text{ V}$$

$$N_{dn,eff}^+ = \underline{\hspace{2cm}} \quad N_{ap,eff}^- = \underline{\hspace{2cm}}$$

$$V_0 = \underline{\hspace{2cm}} \quad V_A = \underline{\hspace{2cm}}$$

(c) [3 points] Express the symbolic values of the energies marked "A", "B" and "C" in the energy band diagram shown above in terms of the parameters  $V_0$  and  $V_A$ .

$$\text{Answers: } A = qV_A$$

$$B = q(V_0 - V_A)$$

$$C = q(V_0 - V_A)$$

$$A = \underline{\hspace{2cm}} \text{ eV} \quad B = \underline{\hspace{2cm}} \text{ eV} \quad C = \underline{\hspace{2cm}} \text{ eV}$$

(d) [3 points] Consider this pn junction **unbiased**. Will the depletion region extend more into the p-side or the n-side, i.e. which is greater  $x_{no}$  or  $x_{po}$ ? (Circle one)

**Answer:  $x_{no} > x_{po}$**

$$x_{no} > x_{po}$$

$$x_{no} < x_{po}$$

Problem Score

/25

(3)

Consider the diode circuit show. Each diode has a turn-on voltage of 0.60 V and reverse saturation current of 0 A. The voltage  $V_R = 4.0$  V and the resistor  $R = 2.0$  k $\Omega$

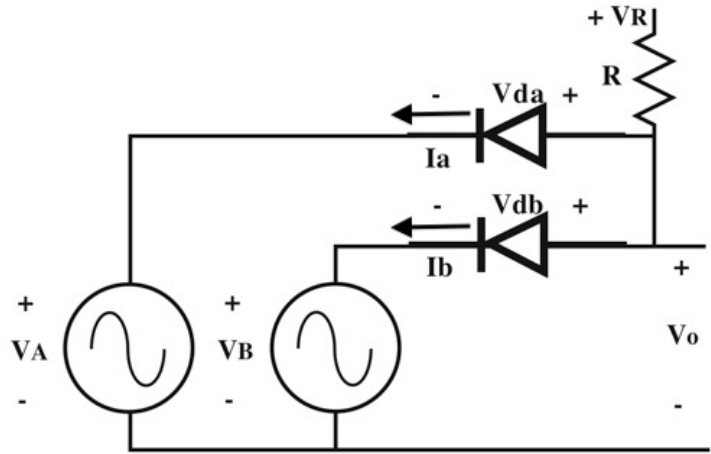

(a) [6 Points] If  $V_A = V_B = 6.0$  V, Calculate  $V_o$ ,  $I_a$ , and  $I_b$ .

**Answers:**

**$V_A = V_B = 6$  V and  $V_R = 4$  V**  
**Diodes Reverse Biased**  
 **$I_A = I_B = -I_o = 0$  A**  
**KVL  $-4 + IR = V_o$  gives  $V_o = 4$  V**

$V_o =$  \_\_\_\_\_  $I_a =$  \_\_\_\_\_  $I_b =$  \_\_\_\_\_

(b) [8 Points] If  $V_A = 0$  V and  $V_B = 6.0$  V, Calculate  $V_o$ ,  $I_a$ , and  $I_b$ .

**Answers:**

**$V_A = 0$  V and  $V_B = 6$  V and  $V_R = 4$  V**  
**Diode A Forward Biased and Diode B Reverse Biased  $I_b = 0$**   
 **$-V_o + V_{dA} + V_A = 0$   $V_o = 0.6$  V**  
**KVL  $-4 + IR = V_o$  gives  $I_a = 1.7$  mA**

$V_o =$  \_\_\_\_\_  $I_a =$  \_\_\_\_\_  $I_b =$  \_\_\_\_\_

(c) [8 Points] If  $V_A = 0$  V and  $V_B = 0$  V, Calculate  $V_o$ ,  $I_a$ , and  $I_b$ .

**Answers:**

**$V_A = V_B = 0$  V and  $V_R = 4$  V**  
**Diodes Forward Biased**  
 **$-V_o + V_{dA} + V_{A,B} = 0$   $V_o = 0.6$  V**  
**KVL  $-4 + IR = V_o$  gives  $I = 1.7$  mA and  $I_{a,b} = I/2 = 0.85$  mA**

$V_o =$  \_\_\_\_\_  $I_a =$  \_\_\_\_\_  $I_a =$  \_\_\_\_\_

(d) [8 Points] What type of system does the above circuit represent? (Circle ne)

OR Gate                      Clamper                      XOR Gate                      None of those listed

**Answers: None Listed (AND Gate)**

Problem Score <div style="text-align: right; font-size: 1.5em;">/25</div>
--

(4)

The two circuits shown need to have equivalent operating points. The circuit values are

$$V_{CC} = 15.0 \text{ V}, V_{BB} = 5.00 \text{ V},$$

$$R_b = 50.0 \text{ k}\Omega, R_e = 0 \Omega, \text{ and } R_C = 500 \Omega.$$

Assume a gain (nominal) of  $\beta = 100$  and a base-emitter turn-on voltage of  $V_{to} = 0.70 \text{ V}$ .

- (a) [10 points] Calculate the required values of  $R_1$  and  $R_2$  for the circuits to be equivalent.

Answers:

$$R_1 = R_B(V_{CC}/V_{BB}) = 150 \text{ kiloOhm}$$

$$R_2 = R_B[V_{CC}/(V_{CC} - V_{BB})] = 75 \text{ kiloOhm}$$

$$R_1 = \underline{\hspace{2cm}}$$

$$R_2 = \underline{\hspace{2cm}}$$

- (b) [9 points] Calculate the currents  $i_C$ ,  $i_E$ , and  $i_B$ .

Answers:

$$-V_{BB} + i_B R_b + 0.7 = 0$$

$$i_B = (5 - 0.7)/[50k] = 0.086 \text{ mA}$$

$$i_C = \beta i_B = (100)(0.086 \text{ mA}) = 8.6 \text{ mA}$$

$$i_E = (\beta + 1) i_B = (201)(0.086 \text{ mA}) = 8.686 \text{ mA}$$

$$i_C = \underline{\hspace{2cm}} \quad i_E = \underline{\hspace{2cm}} \quad i_B = \underline{\hspace{2cm}}$$

- (c) [6 points] Calculate the voltages  $v_{EC}$  and  $V_o$ . Note that  $R_e = 0 \Omega$ .

$$V_o = i_C R_C = (8.6 \text{ mA})(500 \text{ Ohm}) = 4.3 \text{ V}$$

$$v_{EC} = V_{CC} - i_C R_C = 15 - 4.3 = 10.7 \text{ V}$$

$$v_{EC} = \underline{\hspace{2cm}}$$

$$V_o = \underline{\hspace{2cm}}$$

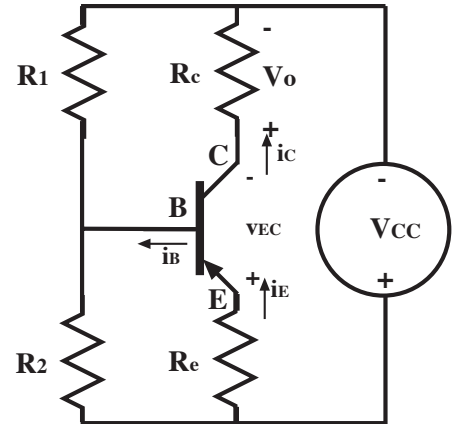
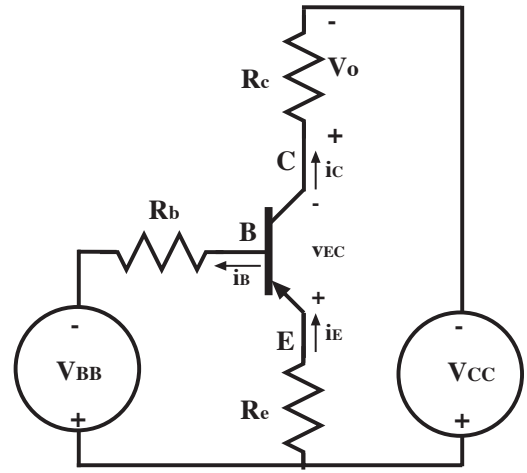

Problem Score

/25

(5)

Consider the BJT circuit shown ( $v_s = 0$ ).

For the bipolar junction transistor,

$$\beta = 200 \text{ (nominal),}$$

$$V_{to} \text{ (turn-on)} = 0.7 \text{ V,}$$

$$V_{CE(SAT)} = 0.20 \text{ V,}$$

For the circuit let

$$V_{BB} = 3.70 \text{ V, } V_{CC} = 12.0 \text{ V,}$$

$$R_b = 10.00 \text{ k}\Omega, R_e = 1.00 \text{ k}\Omega.$$

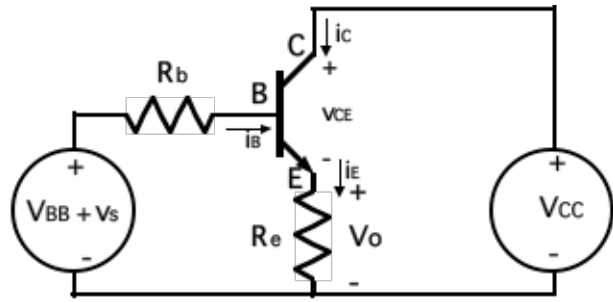

(a) [2 points] Identify the transistor type. (Circle one)

**npn**

**pnp**

**Answer: npn**

(b) [3 points] What type of carrier is largest in the transistor current  $i_C$ ? (Circle one)

**holes**

**electrons**

**Answer: electrons**

(c) [15 points] Calculate the transistor currents  $i_B$ ,  $i_E$ , and  $i_C$ . and the voltages  $V_o$  and  $v_{CE}$ . Express all answer to 3 decimal places.

**Answers:**

$$-V_{BB} + i_B R_b + 0.7 + i_E R_e = 0 \quad -V_{BB} + i_B [R_b + (1 + \beta) R_e] + 0.7 = 0$$

$$i_B = (3.7 - 0.7) / [10k + (201) 1k] = 0.0142 \text{ mA}$$

$$i_C = \beta i_B = (200)(0.0142 \text{ mA}) = 2.844 \text{ mA}$$

$$i_E = (\beta + 1) i_B = (201)(0.0142 \text{ mA}) = 2.858 \text{ mA}$$

$$V_o = i_E R_e = (2.858 \text{ mA})(1\text{kiloOhm}) = 2.858 \text{ V}$$

$$v_{CE} = V_{CC} - i_E R_e = 12 - 2.858 = 9.142 \text{ V}$$

$$i_B = \underline{\hspace{2cm}} \quad i_E = \underline{\hspace{2cm}} \quad i_C = \underline{\hspace{2cm}}$$

$$V_o = \underline{\hspace{2cm}} \quad v_{CE} = \underline{\hspace{2cm}}$$

(d) [5 points] For an unbiased bipolar transistor of the type given in this problem, sketch the equilibrium energy-band diagram. Clearly label the Fermi energy levels  $E_F$  and the intrinsic levels in each region  $E_{i,x}$ . Label each region (collector, base, and emitter).

Problem Score

/25

(6)

- (a) [5 points] For an unbiased **n-channel** JFET, sketch the equilibrium energy-band diagram. Clearly label the Fermi energy level  $E_F$  in each region and the intrinsic energy levels  $E_{i, \text{Gate}}$  and  $E_{i, \text{Channel}}$  in each region. Label each region (channel or gate).

- 
- (b) [5 points] Consider a **p-channel** JFET with specifications  $V_{po}$  and  $I_{SDS}$ . For the saturation case, sketch the curve  $i_{SD}$  vs.  $v_{SG}$ . Label key points of the curve.

- 
- (c) [6 points] Consider an **n-channel** JFET with specifications  $V_{po}$  and  $I_{DSS}$ . On a single graph, sketch the current-voltage curves  $i_{DS}$  vs.  $v_{DS}$  for the following three input voltage cases. Clearly label which curve corresponds to each input voltage case.

- A)  $v_{GS} = 0 \text{ V}$   
B)  $-V_{po} < v_{GS} < 0 \text{ V}$   
C)  $v_{GS} < -V_{po}$

- 
- (c) Consider the circuit shown in which the **n-channel** JFET has the following specification:

$$V_{po} = 4.0 \text{ V} \quad \text{and} \quad I_{DSS} = 2.0 \text{ mA.}$$

The supply voltage is  $V_{DD} = 10.0 \text{ V}$ . The operating current is  $i_{DS} = 1.0 \text{ mA}$ .

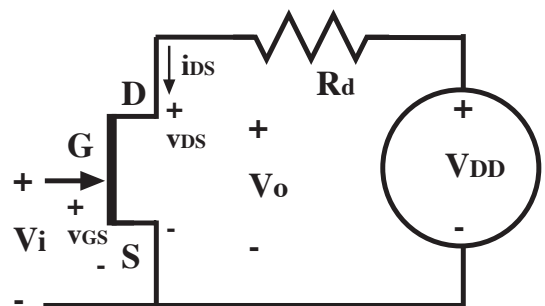

- i) [3 points] Assuming saturation conditions exist, calculate the needed value of  $V_i = v_{GS}$ .

**Answer:**

$$i_{DS} = I_{DSS} [1 + (v_{DS}/V_{PO})]^2$$

$$1 \text{ mA} = (2 \text{ mA}) [1 + (v_{GS}/4)]$$

$$v_{GS} = -1.2 \text{ V}$$

$$V_i = v_{GS} = \underline{\hspace{2cm}}$$

- ii) [6 points] Calculate the resistor value  $R_d$  needed to have the JFET operating voltage  $v_{DS} = 6.0 \text{ V}$

**Answer:**

$$\text{KVL LL is } -V_{DD} + v_{DS} + i_{DS} R_d = 0$$

$$R_d = (V_{DD} - v_{DS})/i_{DS} = (10 - 6)/(0.001) = 4 \text{ kiloOhm}$$

$$R_d = \underline{\hspace{2cm}}$$

Problem Score

/25

(7)

Consider a depletion-mode MOSFET circuit with  $V_{PO} = 4.00 \text{ V}$ ,  $I_{DSS} = 2.00 \text{ mA}$ ,  $i_G = 0 \text{ A}$ , and  $V_{DD} = 15.0 \text{ V}$ .

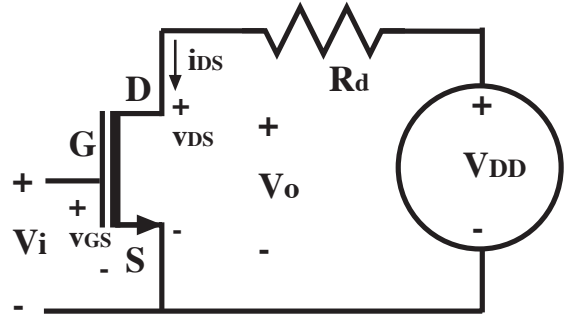

(a) [3 points] Identify the MOSFET type (circle one).

n-channel Depletion-mode MOSFET  
p-channel Depletion-mode MOSFET

**Answer: n-channel**

(b) [6 points] Determine the intercepts in symbolic terms on a ( $i_{DS}$  vs.  $v_{DS}$ ) graph for the load-line KVL, i.e. voltage-axis intercept when current is zero and current-axis intercept when the voltage is zero.

**Answers:**

**KVL LL is  $-V_{DD} + v_{DS} + i_{DS} R_d = 0$**

**When  $i_{DS} = 0$ ,  $v_{DS} = V_{DD}$     When  $v_{DS} = 0$ ,  $i_{DS} = V_{DD}/R_d$**

**Voltage-axis intercept = ( \_\_\_\_\_, 0 A)      Current-axis intercept = (0 V, \_\_\_\_\_)**

(c) [4 points] Calculate the maximum value of  $V_i$  for which the current  $i_{DS} = 0$ .

**Answer:**

**$i_{DS} = 0$  for  $V_i = v_{GS} = -V_{PO} = -4 \text{ V}$ ,**

$V_i =$  \_\_\_\_\_

(d) [8 points] If the current  $i_{DS} = 2.00 \text{ mA}$ , calculate the value of  $R_d$  for which the MOSFET operates at the threshold of saturation.

**Answer:**

**For operation at the threshold and  $i_{DS} = I_{DSS}$ ,  $v_{GS} = 0$ .**

**Then,  $v_{DS} - v_{GS} = v_{DS} - 0 = V_{PO} = 4 \text{ V}$**

**KVL LL is  $-V_{DD} + v_{DS} + i_{DS} R_d = 0$**

**When  $R_d = (1/i_{DS})(V_{DD} - v_{DS}) = (1/0.002)(15 - 4) = 5,500 \Omega$ ,**

$R_d =$  \_\_\_\_\_

(e) [4 points] Let  $v_{GS} = v_{GS,C}$  be the input voltage that produced  $i_{DS} = 2.00 \text{ mA}$  in part c (using the value of  $R_d$  calculated in part c). If the input voltage increases, i.e.  $v_{GS} > v_{GS,C}$ , what is the condition of the MOSFET. (Circle one.)

Saturated Operation

Unsaturated Operation

**Answer: Unsat. Operation**

Problem Score  
/25



(8)

Consider the OpAmp circuit shown. Assume ideal OpAmp parameters.

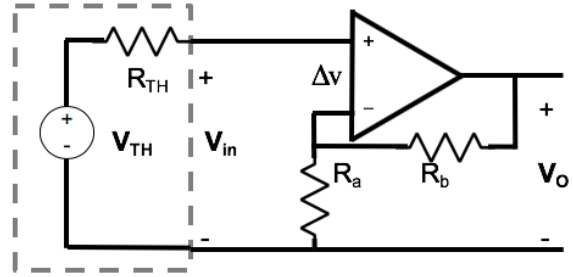

(a) [3 points] For this ideal case, what is the input resistance of the OpAmp? (Circle one.)

$R_{in} = \text{Zero Ohms}$

$R_{in} = 100 \text{ Ohms}$

$R_{in} = 100,000 \text{ Ohms}$

$R_{in} = \text{Infinite Ohms}$

**Answer:  $R_{in} = \text{Infinite Ohms}$**

(b) [3 points] What type of OpAmp circuit is shown? (Circle one.)

**Inverting ( $V_o / V_{TH}$  neg.)**

**Non-Inverting ( $V_o / V_{TH}$  pos.)**

**Answer: Non-Invert**

(c) [12 points] Derive the symbolic expression for the circuit gain  $V_o / V_{TH}$  in terms of the resistances.

**Answer:**

**By KVL (no current into ideal OpAmp)  $V_+ = V_{in} = V_{TH}$**

**$V_+ = V_-$  since  $\Delta v = 0$  (negative feedback).**

**By voltage division (no current into ideal OpAmp)  $V_- = [(R_a)/(R_a + R_b)]V_o$**

**$V_o = [(R_a + R_b)/R_a]V_- = [(R_a + R_b)/R_a] V_{TH}$  (non-inverting case)**

**$V_o / V_{TH} = [(R_a + R_b)/R_a]$  or  $[1 + (R_b/R_a)]$  (non-inverting case)**

$V_o / V_{TH} = \underline{\hspace{2cm}}$

(d) [7 points] The circuit values are

$R_{TH} = 5.00 \text{ k}\Omega$ ,  $R_a = (1 - x) 4.00 \text{ k}\Omega$ , and  $R_b = x 4.00 \text{ k}\Omega$ .

Let the voltage across  $R_a$  be  $V_A$ . If  $|V_o/V_A| = 6$ , calculate the needed value of the fraction  $x$ .

**Answer:**

**By voltage division (no current into ideal OpAmp)  $V_A = [(R_a)/(R_a + R_b)]V_o$**

**$V_o = [(R_a + R_b)/R_a]V_A$  (non-inverting case)**

**$V_o / V_A = [(R_a + R_b)/R_a] = [1 + (R_b/R_a)] = \{1 + xR/[(1-x)R]\} = 1 + x/(1 - x)$**

**$V_o / V_A = (1 - x)/(1 - x) + x/(1 - x) = 1/(1 - x) = 6$**

**$x = 5/6$**

$x = \underline{\hspace{2cm}}$

Problem Score

/25

(9)

Consider the OpAmp circuit shown.

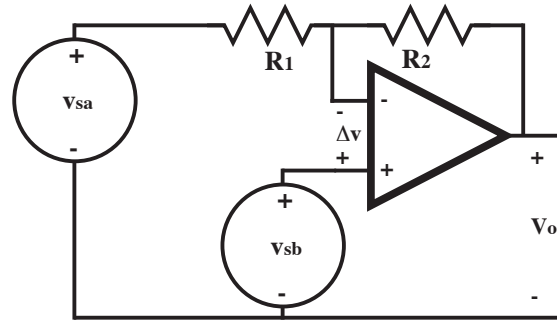

- (a) [5 points] Sketch the equivalent circuit in which the OpAmp is replaced with appropriate circuit elements. Assume **ideal** values for the OpAmp resistances.

- (b) [10 points] Use superposition to derive the influence of just the input  $v_{sb}$  with  $v_{sa} = 0$ , i.e.  $V_{0,b}$  as a function of the resistances  $R_1$  and  $R_2$  and voltage  $v_{sb}$ . Assume an **ideal** OpAmp.

**Answer ( $v_{sa} = 0$  gives a short)**

**By Voltage Division**

$$V_- = [R_1 / (R_1 + R_2)] V_{0,b}$$

**Negative Feedback produces**

$$v_{sb} = V_+ = V_- = [R_1 / (R_1 + R_2)] V_{0,b}$$

$$V_{0,b} = [1 + (R_2 / R_1)] v_{sb}$$

$$V_{0,b} = \underline{\hspace{10em}}$$

- (c) [10 points] The resistance values are  $R_1 = 2.00 \text{ k}\Omega$  and  $R_2 = 10.00 \text{ k}\Omega$ . If the input voltage  $v_{sb} = 6 \text{ V}$ , calculate the input voltage  $v_{sa}$  which gives zero for the (total) output voltage, i.e.  $V_0 = 0$ . Assume an **ideal** OpAmp.

**Answer**

**Negative Feedback gives  $v_{sb} = V_+ = V_- = 6 \text{ V}$ .**

**KCL at “-“ gives**

$$(v_{sb} - v_{sa}) / R_1 + (v_{sb} - V_0) / R_2 = 0$$

$$(6 - v_{sa}) / R_1 + (6 - 0) / R_2 = 0$$

$$v_{sa} = R_1 [(6 / R_1) + (6 / R_2)] = (2000) [(6 / 2000) + (6 / 10000)] = 7.20 \text{ V}$$

**Alternative**

**Superposition Non-inverting**

$$V_{0,b} = [1 + (R_2 / R_1)] v_{sb} = [1 + (10000 / 2000)] 6 = 36 \text{ V}$$

**Superposition Inverting**

$$V_{0,a} = - (R_2 / R_1) v_{sa} = - (10000 / 2000) v_{sa} = - 5 v_{sa}$$

$$\text{Hence, } V = 0 \text{ for } V_{0,a} = - 5 v_{sa} = - 36 \text{ V}$$

$$v_{sa} = 36 / 5 = 7.20 \text{ V}$$

$$v_{sa} = \underline{\hspace{10em}}$$

Problem Score

/25

(10)

- (a) [12 points] Consider crystalline Si which has a bandgap energy of  $E_G = 1.12$  eV. Complete the table with the correct calculation and selection, i.e. calculate the photon energies of these wavelengths and note whether Si is absorbing or transparent.

Wavelength	Photon Energy in eV	Si is (circle one)
900 nm		<b>Absorbing</b> <b>Transparent</b>
1500 nm		<b>Absorbing</b> <b>Transparent</b>

**Answer**

$$E_P = hc/\lambda = (4.136 \times 10^{-15} \text{ eV}\cdot\text{s}) (2.998 \times 10^{10} \text{ cm/s}) / (0.9 \times 10^{-4} \text{ cm}) = 1.38 \text{ eV}$$

**Absorbing since  $E_P > E_G$**

$$E_P = hc/\lambda = (4.136 \times 10^{-15} \text{ eV}\cdot\text{s}) (2.998 \times 10^{10} \text{ cm/s}) / (1.5 \times 10^{-4} \text{ cm}) = 0.827 \text{ eV}$$

**Transparent since  $E_P < E_G$**

Consider the Si pin photodiode circuit shown with source voltage  $V_S = -12.0$  V and with load resistance  $R = 5000$  Ohms. The reverse saturation current (for "dark" conditions) is 0.20 mA. Assume the photodiode voltage  $|V| \gg kT/q$  and room temperature.

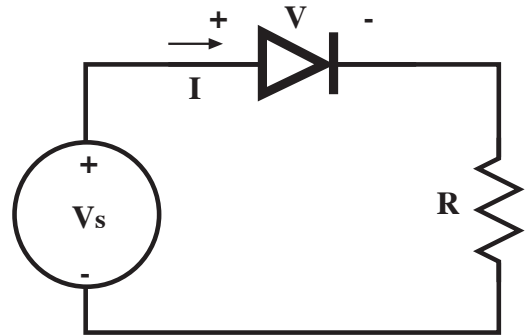

- (b) [6 points] Calculate the photodiode operating point for dark conditions (no incident light).

**Answers:**

**For Dark Conditions,  $I = -I_0 = -0.20$  mA**

**KVL LL is  $-V_S + V + IR = 0$**

**$V = V_S - IR = (-12) - (-0.20 \text{ mA})(5000 \text{ Ohms}) = -11.0$  V**

**$V =$  \_\_\_\_\_  **$I =$  \_\_\_\_\_****

- (c) [7 points] Calculate the photodiode operating point for conditions in which the photo-induced current  $I_{\text{light}} = 1.00$  mA. (The incident light is at an absorbing wavelength).

**Answers:**

**For these conditions,  $I = -I_0 - I_{\text{light}} = -0.20 - 1.0 \text{ mA} = -1.2$  mA**

**KVL LL is  $-V_S + V + IR = 0$**

**$V = V_S - IR = (-12) - (-1.20 \text{ mA})(5000 \text{ Ohms}) = -6.0$  V**

**$V =$  \_\_\_\_\_  **$I =$  \_\_\_\_\_****

Problem Score

/25