

Name: _____

Instructor: _____

Section/College: _____

Major: Electrical Engineering Computer Engineering (Check one)

Electrical Engineering Advancement Exam I

FALL SEMESTER 2020

CLOSED BOOK, CLOSED NOTES

2 HOUR TIME LIMIT

CALCULATORS ARE ALLOWED

(calculators without communication capability only)

ELECTRONIC DEVICES WITH COMMUNICATION CAPABILITY

MAY NOT BE USED DURING THE EXAMINATION

(electronic devices such as cell phone, pagers, and iPads)

(If such devices ring or are visible,

a 10% penalty will be given for the first occurrence and exam failure for the second.)

There are 10 problems: please look over the exam to make sure that you have 10 different problems. **Do any eight (8) problems!** Draw a large X through the two problems that you do not want to be graded. If you do not indicate which problems you want to leave out, the first 8 problems will be graded.

Do all work for each problem only on the page supplied for that problem (you may use both sides). **DO NOT**, for instance, continue Problem #3 on the back of Problem #2. Extra blank paper will be supplied if needed. If extra paper is used, show the additional work for each problem on a separate sheet, write your name and problem number on the sheet, and staple the extra sheet(s) to the appropriate problems.

(1) For the given circuit,

- Calculate the current i_x . (6 pts.)
- Calculate the power absorbed by the $5\text{-}\Omega$ resistor. (6 pts.)
- Calculate voltage v_x . (6 pts.)
- Calculate the power absorbed by the dependent source. Is it absorbing or supplying power? (7 pts.)

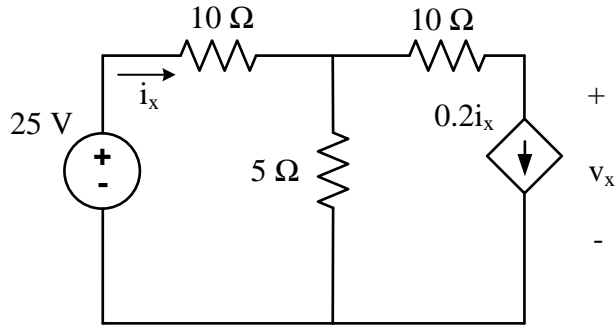

$i_x =$ _____

$p_{5\Omega} =$ _____

$v_x =$ _____

$p_{dep} =$ _____ absorbed or supplied
(circle one)

Problem Score _____ / 25

(2) Write a set of node voltage equations for the following circuit in matrix form. You must eliminate the control variable from your node voltage equations. Solve for all the node voltages. (25 pts)

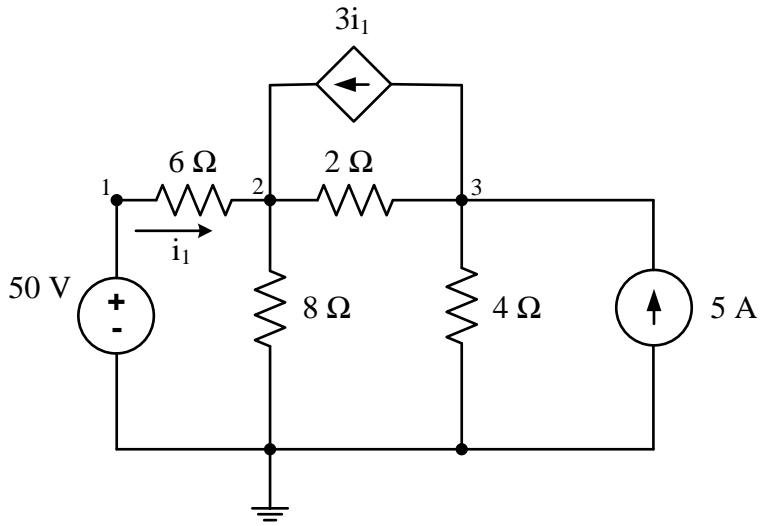

$$\begin{bmatrix} \\ \\ \end{bmatrix} \begin{bmatrix} v_1 \\ v_2 \\ v_3 \end{bmatrix} = \begin{bmatrix} \\ \\ \end{bmatrix}$$

$v_1 =$ _____ $v_2 =$ _____ $v_3 =$ _____

(3) Write a set of mesh current equations for the following circuit in matrix form. You must eliminate the control variable from your mesh current equations. Solve for all the mesh currents. (25 pts)

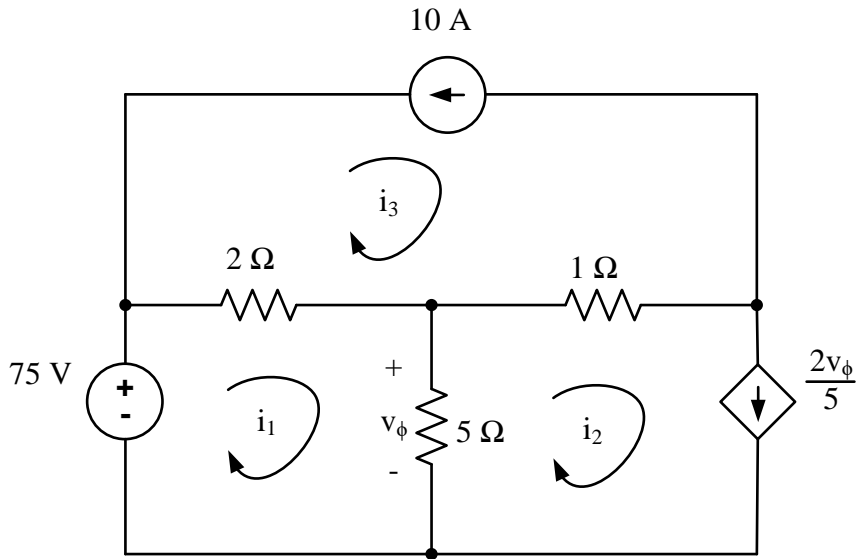

$$\begin{bmatrix} \\ \\ \end{bmatrix} = \begin{bmatrix} i_1 \\ i_2 \\ i_3 \end{bmatrix} = \begin{bmatrix} \\ \\ \end{bmatrix}$$

$i_1 =$ _____ $i_2 =$ _____ $i_3 =$ _____

- (4) Use a series of source transformations to determine an equivalent circuit with respect to terminals a and b consisting of a current source and parallel resistance. Sketch the equivalent circuit.

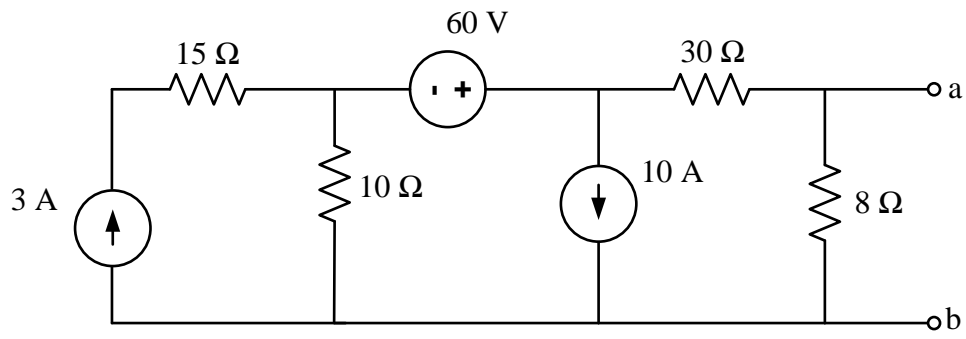

Equivalent Circuit

(5) For the circuit below,

- Find and sketch the Norton equivalent circuit with respect to the terminals a and b . (15 pts)
- Find the load resistance, R_L , which should be attached between the end terminals a and b so that maximum power is delivered to the load. (3 pts)
- Calculate the value of the maximum power delivered to the load. (7pts)

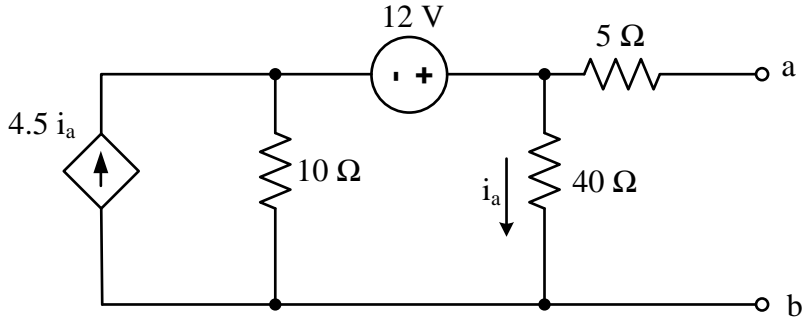

$R_L =$ _____

$P_{\max} =$ _____

Norton Equivalent Circuit

(6) Use superposition to calculate the voltage, v , in the following circuit. Sketch the circuits for each step of the superposition. (25 pts.)

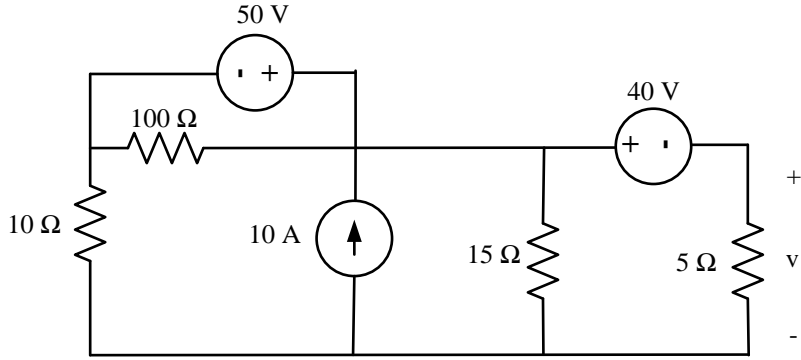

$v =$ _____

(7) Answer the following questions. Parts *a* and *b* refer to the voltage shown in the graph below.

- Write an equation for $v(t)$ utilizing the step unit function [note: $\omega = 2\pi f = 2\pi/T$]. (7 pts.)
- Calculate the average voltage v_{avg} on the interval $0 < t < T$. (10 pts.)
- Calculate the average power dissipation P_{av} when a voltage

$v_2(t) = 15 \cos\left(4000\pi t - \frac{\pi}{6}\right)$ V is applied across a resistor of 10 ohms. (8 pts.)

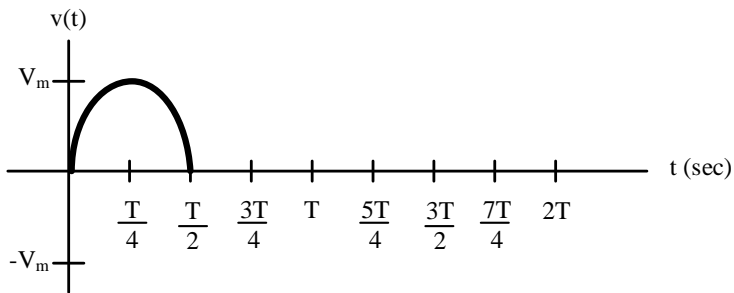

$v(t) =$ _____

$V_{avg} =$ _____

$P_{av} =$ _____

Name _____

Problem Score
/ 25

(8) Answer the following questions when $v(0^-) = 4 \text{ V}$.

- Determine $v(0^+)$. (3 pts.)
- Determine $v(t)$ for $t > 0$. (10 pts.)
- Determine $i(t)$ and $i_1(t)$ for $t > 0$. (7 pts.)
- Determine the time constant (5 pts.)

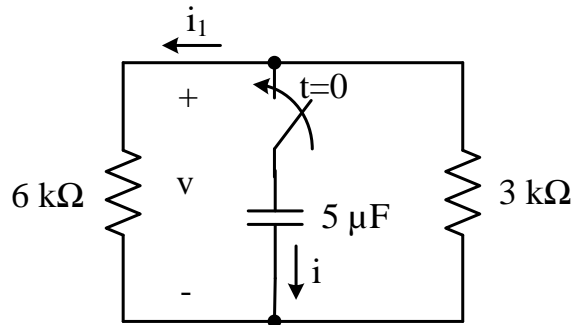

$v(0^+) =$ _____

$v(t) =$ _____

$i(t) =$ _____

$i_1(t) =$ _____

$\tau =$ _____

(9) Answer the following questions.

- Sketch the most simplified equivalent circuit for $t=0^-$ and determine $i(0^+)$. (5 pts.)
- Determine the particular solution, $i_p(t)$ for $t>0$. (8 pts.)
- Calculate $i(t)$ for $t>0$. (7 pts.)
- Sketch the most simplified equivalent circuit for $t=\infty$ and determine $i(\infty)$. (5 pts.)

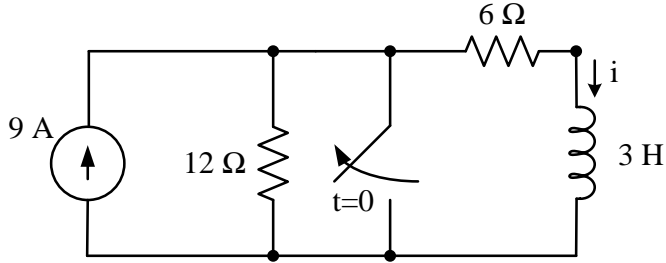

$i(0^+) =$ _____

$i_p(t) =$ _____

$i(t) =$ _____

$i(\infty) =$ _____

(10) For the following RLC circuit, given that $v_s = 10e^{-5t} \text{ V}$ $t > 0$, assume that the initial conditions for the inductor and capacitor are $i(0) = 20\text{A}$ and $v(0) = 10\text{V}$.

- Write a differential equation, in terms of v , to find the voltage across the capacitor $t > 0$. (5 pts)
- Find the initial condition $v'(0^+) = \left. \frac{dv}{dt} \right|_{t=0^+}$. (4pts)
- Find the form of the natural response $v_n(t)$ $t > 0$. (6 pts)
- What type of damping exists in this circuit? overdamped, underdamped or critically damped? (3pts)
- Solve for the particular solution $v_p(t)$ $t > 0$. (7pts)

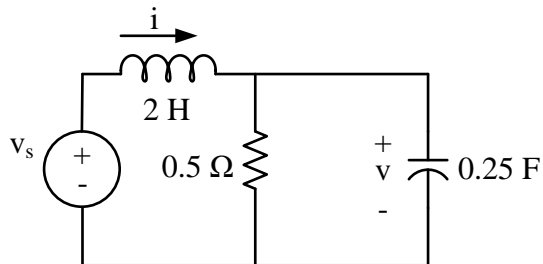

Diff. Eqn.: _____

$$v'(0^+) = \left. \frac{dv}{dt} \right|_{t=0^+} = \underline{\hspace{4cm}}$$

$v_n(t) = \underline{\hspace{4cm}}$

Dampening (circle one): Overdamped Underdamped Critically Damped

$v_p(t) = \underline{\hspace{4cm}}$

Problem Score
/ 25

EE 2100 (Circuits-I) Equation Sheet

First-order circuits

$$v_n(t) = K e^{st} = v_n(0^+)e^{st} \quad (s = -1/\tau, \tau = RC \text{ or } L/R)$$

$$v_p(t) = A \text{ (constant source)}$$

$$= Ae^{s_p t} \text{ (exponential source; } s \neq s_p)$$

$$= Ate^{s_p t} \text{ (exponential source; } s = s_p)$$

$$v(t) = v_p(t) + [v(0^+) - v_p(0^+)]e^{st} = v(\infty) + [v(0^+) - v(\infty)]e^{st}$$

(constant source)

$$\frac{dy}{dt} + ay = b(t) \Rightarrow y(t) = Ae^{-at} + e^{-at} \int_0^t b(\tau) e^{+a\tau} d\tau \quad \text{where } A = y(0^+)$$

Second-order circuits

$$s_1, s_2 = -\alpha \pm \sqrt{\alpha^2 - \omega_o^2} \text{ or } -\alpha \pm j\omega_d$$

$$(\alpha = R / 2L \text{ or } 1 / 2RC, \omega_o = 1 / \sqrt{LC}, \omega_d = \sqrt{\omega_o^2 - \alpha^2})$$

$$v_n(t) = A_1 e^{s_1 t} + A_2 e^{s_2 t} \text{ (overdamped)}$$

$$= (A_1 + A_2 t)e^{-\alpha t} \text{ (critically damped)}$$

$$= (A_1 \cos \omega_d t + A_2 \sin \omega_d t)e^{-\alpha t} \text{ (underdamped)}$$

$$v_p(t) = A \text{ (constant sources)}$$

$$= Ae^{s_p t} \text{ (exponential source; } s \neq s_p)$$

$$= Ate^{s_p t} \text{ (exponential source; } s = s_p)$$

Euler's identity

$$e^{j\omega t} = \cos \omega t + j \sin \omega t \quad e^{-j\omega t} = \cos \omega t - j \sin \omega t$$

$$\cos \omega t = \operatorname{Re}\{e^{j\omega t}\} = \frac{(e^{j\omega t} + e^{-j\omega t})}{2} \quad \sin \omega t = \operatorname{Im}\{e^{j\omega t}\} = \frac{(e^{j\omega t} - e^{-j\omega t})}{j2}$$

Problem Score

/ 25
