

# EE3501, Experiments 7-8

## Induction Machines

Jonathan Kimball, August 31, 2020

### Abstract

Over the course of two laboratory sessions, this experiment explores squirrel-cage induction motors (IMs). IMs are widely used in industrial applications, from a size somewhat smaller than the lab machines (about 100 W or so) to a few megawatts. During the first week, students will find the parameters of the motors in the laboratory. Then in the second week, students will explore the motor's behavior.

## 1 Introduction

Since its invention by Nikola Tesla in the 1800s, the induction motor has remained the most popular type of motor for industry applications. The primary advantage of the induction motor is its straightforward rotor construction leading to low cost, ruggedness, and low-maintenance requirements. In this lab, we will be working with a *squirrel-cage induction motor*, in which the rotor-side winding comprises a cast aluminum cage.

The per-phase equivalent circuit for an induction motor is given in Figure 1. The impedances (all given in  $\Omega$ ) are

$R_1$ : stator resistance

$X_1$ : stator leakage reactance; sometimes  $X_{\ell 1}$

$X_m$ : magnetizing reactance

$R_c$ : core loss resistance

$X_2$ : rotor leakage reactance; sometimes  $X_{\ell 2}$

$R_2$ : rotor resistance

Please note that in a squirrel-cage structure,  $R_2$  and  $X_2$  cannot actually be measured directly, since there are no terminals on the rotor. Otherwise, this model closely resembles the Steinmetz (T-equivalent) model of a transformer, shorted on the secondary (rotor).

The core loss (due to hysteresis and eddy currents) is nonlinear and can only be *approximated* by  $R_c$ . Also, distinguishing core loss from windage and friction is very difficult. For both of these reasons,  $R_c$  is frequently omitted.

The electrical variables are:

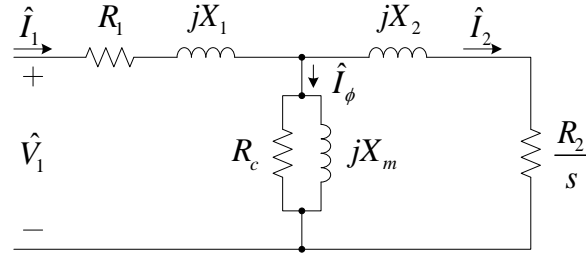

Figure 1: Per-phase equivalent circuit model of induction motor.

$\hat{V}_1$ : motor phase voltage (line-to-neutral)

$\hat{I}_1$ : motor phase current (stator-side; typically also the line current)

$\hat{I}_m$ : magnetizing current

$\hat{E}_1$ : equivalent voltage across magnetizing circuit

$\hat{I}_2$ : rotor current (equivalent)

$s$ : slip

The slip is an important variable that determines behavior. There are many equivalent definitions:

$$s = \frac{\omega_s - \omega_m}{\omega_s} \quad (1)$$

$$= \frac{n_s - n}{n_s} \quad (2)$$

$$= \frac{\omega_{re}}{\omega_e} \quad (3)$$

$$= \frac{f_{re}}{f_e} \quad (4)$$

where  $\omega_s$  is the synchronous speed,  $\omega_m$  is the actual speed,  $n$  is the actual speed in RPM,

$$n_s = \frac{120f_e}{poles} \quad (5)$$

is the synchronous speed,  $f_e$  is the (stator) electrical frequency,  $f_{re}$  is the rotor electrical frequency, and  $\omega_e$ ,  $\omega_{re}$  are the electrical frequencies in  $\text{rad} \cdot \text{s}^{-1}$ .

The impedances can be combined in logical ways to ultimately find the input impedance:

$$\bar{Z}_1 = R_1 + jX_1 \quad (6)$$

$$\bar{Z}_m = R_c \parallel (jX_m) \quad (7)$$

$$\bar{Z}_2 = \frac{R_2}{s} + jX_2 \quad (8)$$

$$\bar{Z}_f = \bar{Z}_m \parallel \bar{Z}_2 \quad (9)$$

$$\bar{Z}_{in} = \bar{Z}_1 + \bar{Z}_f = Z_{in}/\theta \quad (10)$$

Naturally,  $\theta$  is the power factor angle.

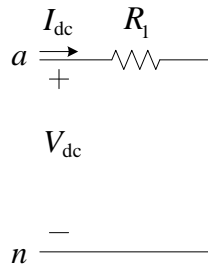

Figure 2: DC test when neutral is available.

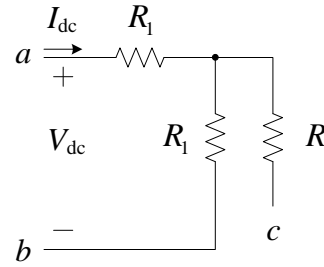

Figure 3: DC test line-to-line on a three-phase motor.

### 1.1 Measuring Equivalent Circuit Model Parameters

Three simple tests can be used to find the circuit parameters. The first is a dc test to find  $R_1$ . In principle, this can be performed with an ohmmeter, but more typically, a dc source and meter are used so that the test may be performed at rated current. Copper has a fairly substantial temperature coefficient of resistivity (about  $393 \text{ m}\% \cdot ^\circ\text{C}^{-1}$ ), so resistance at operating current and temperature can be substantially higher than cold conditions.

The test configuration is shown in Figure 2. The test results are used to find

$$R_{dc} = \frac{V_{dc}}{I_{dc}} \tag{11}$$

Remember that all of the reactances in Figure 1 go to zero at dc. If the neutral is available, then  $R_{dc} = R_1$ . More commonly, only the lines are available, so the more complicated circuit of Figure 3 applies. In that case,

$$R_1 = 1/2 R_{dc} \tag{12}$$

**No Load:** Like an open-circuit test on a transformer, a no-load test primarily provides information about the magnetizing portion of the circuit. Rated voltage (at rated frequency) is applied with no load on the shaft. Assuming low friction, slip will approach zero and the mechanical speed will approach synchronous speed. The rotor-side circuit is essentially an open-circuit and can be ignored. A wattmeter is used to measure voltage, current, and active power. We calculate:

$$S_{nl} = 3V_{1,nl}I_{1,nl} \tag{13}$$

$$Q_{nl} = \sqrt{S_{nl}^2 - P_{nl}^2} \tag{14}$$

$$X_{nl} = \frac{Q_{nl}}{3I_{1,nl}^2} \tag{15}$$

Notice that we are using per-phase quantities, i.e. line-to-neutral voltage. From the equivalent circuit,

$$X_{nl} = X_1 + X_m \tag{16}$$

Once we have  $X_1$ , we can find  $X_m$ .

**Blocked Rotor:** The nearest equivalent to a short-circuit test is achieved by physically preventing the rotor from turning. A low voltage is applied, at a low frequency  $f_{bl}$  if possible.

Ideally, the rated current should flow for the same reasons as for the dc test. When the rotor is blocked,  $\omega_m = 0$  and  $s = 1$ . If all of the parameters are included, the relationship between test results and machine parameters is complicated. However, when  $X_2 \ll X_m$  (which is true in most practical machines), the relationship simplifies.

We again use a wattmeter to measure voltage, current, and active power and calculate:

$$S_{bl} = 3V_{1,bl}I_{1,bl} \quad (17)$$

$$Q_{bl} = \sqrt{S_{bl}^2 - P_{bl}^2} \quad (18)$$

$$R_{bl} = \frac{P_{bl}}{3I_{1,bl}^2} \quad (19)$$

$$X_{bl} = \frac{f_{rated}}{f_{bl}} \frac{Q_{bl}}{3I_{1,bl}^2} \quad (20)$$

where typically  $f_{rated} = f_{nl}$ . We can then find the motor parameters from

$$X_2 = (X_{bl} - X_1) \left( \frac{X_{nl} - X_1}{X_{nl} - X_{bl}} \right) \approx X_{bl} - X_1 \quad (21)$$

$$R_2 = (R_{bl} - R_1) \left( \frac{X_2 + X_m}{X_m} \right)^2 \quad (22)$$

The approximation in (21) is valid as long as  $X_2 \ll X_m$ , which is true in most practical machines.

One last problem remains: distinguishing between  $X_1$  and  $X_2$ . The relationship between them depends on the motor construction. The National Electrical Manufacturers Association (NEMA) defines four classes, which have different speed regulation, stall torque, breakdown torque, and starting current. Empirically, NEMA has determined the relationships given in Table 1.

Table 1: NEMA Motor Data

| Class | Description                                     | Fraction of $X_{bl}$ |       |
|-------|---|----------------------|-------|
|       |   | $X_1$                | $X_2$ |
| A     | Normal starting torque, normal starting current | 0.5                  | 0.5   |
| B     | Normal starting torque, low starting current    | 0.4                  | 0.6   |
| C     | High starting torque, low starting current      | 0.3                  | 0.7   |
| D     | High starting torque, high slip                 | 0.5                  | 0.5   |

## 1.2 Steady-State Performance

The torque produced by an induction motor is determined by the power dissipated in the rotor-side equivalent resistance. In Figure 1,  $R_2$  represents a real resistance. The rest of the resistance is a model of the mechanical power. That is, the power that cross the air-gap to the rotor is

$$P_{gap} = 3I_2^2 \frac{R_2}{s}, \quad (23)$$

the power dissipated in the rotor (termed “copper loss” despite the cage being made of aluminum) is

$$P_{rcl} = 3I_2^2 R_2, \quad (24)$$

and the mechanical power is

$$P_{mech} = P_{gap} - P_{rcl} = 3I_2^2 R_2 \frac{1-s}{s} \quad (25)$$

Since mechanical power is torque times speed,

$$T_{mech} = \frac{3I_2^2 R_2}{\omega_m} \frac{1-s}{s} \quad (26)$$

It is difficult to use this expression directly because  $I_2$  is the magnitude of an unmeasurable current. However, the circuit can be analyzed to find a Thévenin equivalent, which is then used to calculate  $\hat{I}_2$ . Also, we may invoke the slip relationships to eliminate  $\omega_m$ . The result is:

$$\hat{V}_{1,eq} = \hat{V}_1 \left( \frac{jX_m}{R_1 + j(X_1 + X_m)} \right) \quad (27)$$

$$\bar{Z}_{1,eq} = \frac{jX_m (R_1 + jX_1)}{R_1 + j(X_1 + X_m)} \quad (28)$$

$$T_{mech} = \frac{1}{\omega_s} \frac{3V_{1,eq}^2 (R_2/s)}{(R_{1,eq} + (R_2/s))^2 + (X_{1,eq} + X_2)^2} \quad (29)$$

The speed-torque characteristic typical of a NEMA class B induction motor is illustrated in Figure 4. At no load, actual speed matches the synchronous speed. As load increases, the motor slows down; initially, the relationship is linear, then quadratic. Normal operation is between no-load and rated torque, which is about  $1/3$  or so of the maximum torque. As load increases, the motor continues to slow down. At maximum torque, also called *breakdown torque*, the motor crosses into an unstable regime and normally, the speed collapses to zero. The torque produced at zero speed is the *stall torque*, which is the same as the starting torque. There is usually a slight rise in the torque-speed characteristic near zero speed due to skin effect in the rotor bars.

Power losses in an induction motor on the electrical side include stator copper loss<sup>1</sup> ( $P_{scl} = 3I_1^2 R_1$ ), rotor copper loss ( $P_{rcl} = 3I_2^2 R_2$ ), and core loss ( $P_c$  or  $P_{core}$ ). The electromechanical power then is

$$P_{mech} = P_{in} - P_{scl} - P_{rcl} - P_c \quad (30)$$

There is then loss due to friction and windage on a rotating object,  $P_{rot}$ . So the power actually delivered by the shaft to a load is

$$P_{shaft} = P_{mech} - P_{rot} \quad (31)$$

Often,  $P_c$  and  $P_{rot}$  are simply lumped together. The efficiency is

$$\eta = \frac{P_{shaft}}{P_{in}} \quad (32)$$

as usual.

---

<sup>1</sup>“Copper loss” is a typical phrase used to denote loss due to Ohm’s Law, whether or not the conductor is actually copper.

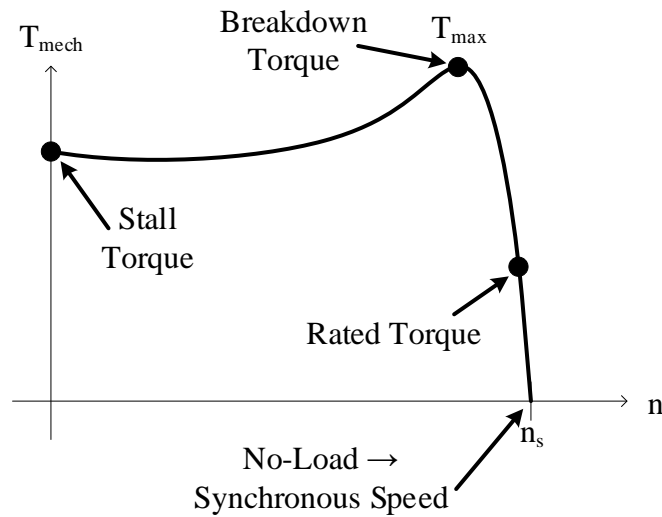

Figure 4: Typical torque-speed curve of a NEMA class B motor.

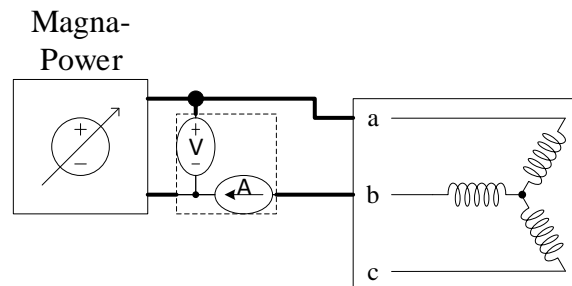

Figure 5: Configuration for dc test.

## 2 Laboratory Software

This set of experiments will require the use of the Magna-Power supply, Flukes, Yokogawa....

## 3 Laboratory Experiment

### 3.1 Week 1: Finding Parameters

Finding the parameters of an induction machine requires three tests. **Before beginning**, make note of the ratings given on the nameplate of the motor that are appropriate for 208 V operation.

**DC Test** : Connect as in Figure 5. You may use any of the three Flukes, configured to measure dc voltage and current. Increase the Magna-Power current to the rating of the motor. Record the voltage and current, which corresponds to the total resistance measured line-to-line. The per-phase stator resistance will be *half* the measured resistance. Turn off the supply.

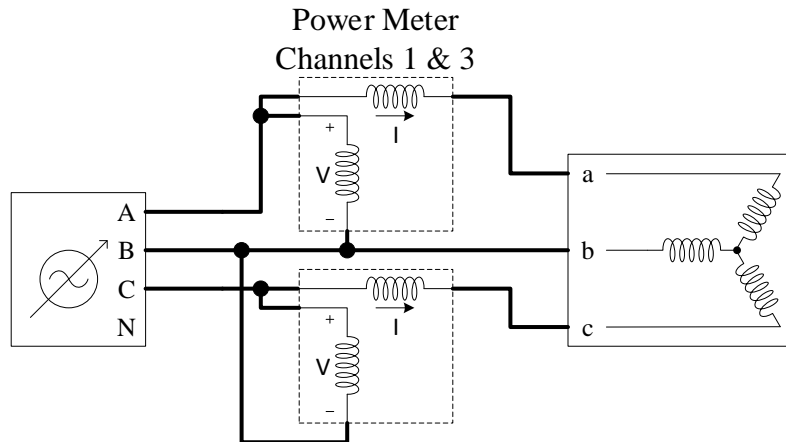

Figure 6: Configuration for ac tests, no-load and blocked-rotor.



Figure 7: Plastic piece used to block the rotor.

**Blocked Rotor Test** : Connect as in Figure 6. Using the hard, white plastic devices shown in Figure 7, block the rotor so that it cannot turn.<sup>2</sup> With the variac set to zero, switch it on, and then slowly increase the voltage until meeting the current rating of the motor. Record this data and shut off the variac source.

**No-Load Test** : Connect as in Figure 6, without the blocking device on the shaft. Switch on the variac and increase to 100%. Record this data and shut off the source.

As noted in Section 4, use the dc, blocked rotor, and no-load test results to determine machine parameters.

### 3.2 Week 2: Performance Testing

Check that the 208 V switches (both at the bottom of the rack and next to the variac) are off. Connect the machines as in Figure 8. The induction and dc machines must be coupled together. Set both Flukes to measure dc voltage and current. Configure the load box as in Figure 9. **Turn on the load box fans.**

<sup>2</sup>In years past, students have been asked to “hold the motor shaft.” **Do not do that!**

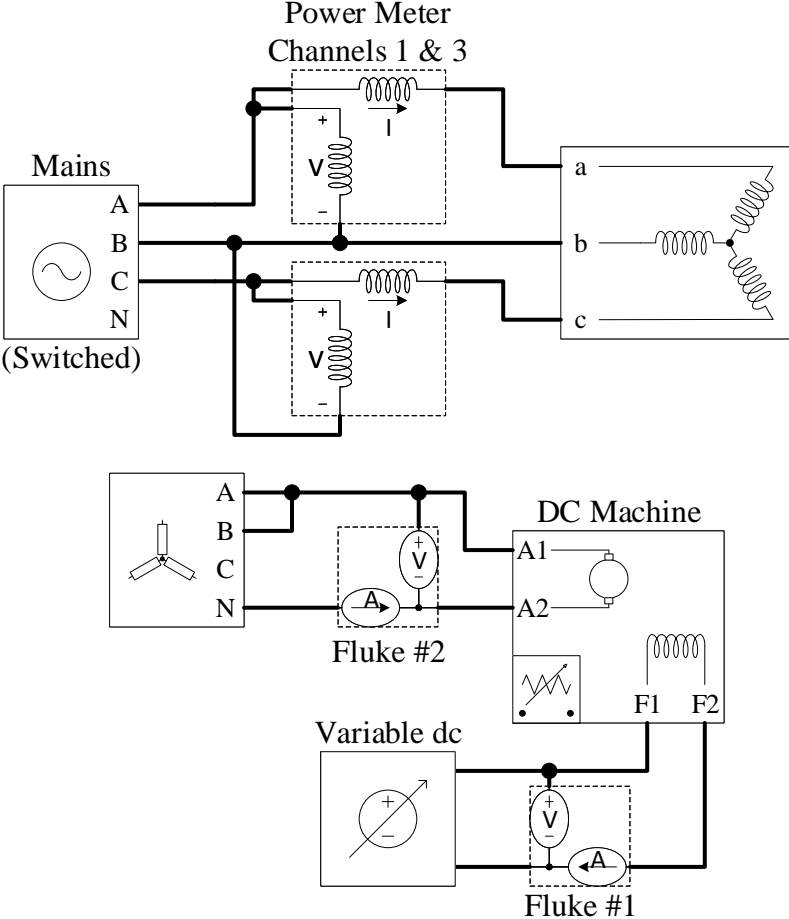

Figure 8: Configuration for load (performance) testing.



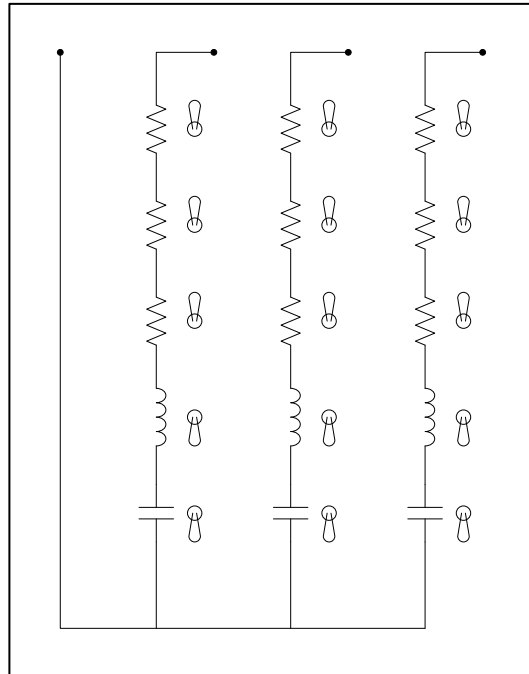

Figure 9: Load box settings for load testing.

Turn on the main 208 V switch. The induction motor will start and go to its no-load speed. (This is called DOL or direct-on-line starting.) Use the hand-held tachometer to measure the motor speed. Record this speed along with the Yokogawa and Fluke data.

Starting with the variac at zero, turn it on and slowly increase it until Fluke #1 (field current) measures approximately 50 mA. The motor should slow down, and the input and output power should increase. Record the speed and the Yokogawa and Fluke data.

Continue increasing the variac to increase the field current in 50 mA increments up to 400 mA, each time recording speed and Yokogawa and Fluke data.

When you have obtained all needed data points, turn off the variac and decrease it to zero, and then the main 208 V switch.

## 4 Calculations and Question

1. Based on the machine ratings, compute the following quantities at rated speed: slip, torque (in newton-meter), input power (in watts), and power factor.
2. Using the dc, no-load, and blocked-rotor test data, determine the machine parameters (see Figure 1).
3. Using this model and the voltage applied during the performance testing experiment, plot both torque and input current vs. speed over a speed range from zero to synchronous speed.
4. Again using the model, create the following plots vs. speed, for a speed range from zero to synchronous speed:

- (a) Input power, stator losses, core+windage losses, rotor losses, mechanical power  
( $P_{in}$ ,  $P_{scl}$ ,  $P_{core}$ ,  $P_{rcl}$ ,  $P_{mech}$ )
  - (b) Input active and reactive power ( $P_{in}$ ,  $Q_{in}$ )
  - (c) Efficiency and power factor
5. Create a table of measured speed, measured current, measured input power, measured output power (dc generated power), estimated mechanical power (mean of input and output), estimated torque, calculated current, and calculated torque (where calculations use the model). Also plot measured and calculated current vs. speed. Explain discrepancies.
  6. Similarly, create a table of measured speed, measured active and reactive power, measured power factor, calculated active and reactive power, and calculated power factor. Also plot measured and calculated active power vs. speed. Explain discrepancies.