

EE 3101 ELECTRONICS I LABORATORY

EXPERIMENT 4 LAB MANUAL

TRANSISTOR BIAS DESIGN AND STABILITY

OBJECTIVES

In this experiment you will

- Learn how to design the bias network for a common-emitter amplifier.
- Observe how close actual circuit currents and voltages compare to design values.
- Become familiar with the laboratory layout and equipment.

LAB NOTEBOOKS

The format of lab notebooks should be such that the information can be used to reproduce the lab, including what values were used in a circuit, why the values were used, how the values were determined, and any results and observations made. This lab manual will be used as a guide for what calculations need to be made, what values need to be recorded, and various other questions. The lab notebook does not need to repeat everything from the manual verbatim, but it does need to include enough information for a 3rd party to be able to use the notebook to obtain the same observations and answers. In the following numbered sections there are **bolded words and/or lines**. These bolded words and/or lines are statements and/or questions that the lab TA will be looking for an answer either in the lab preliminary, or lab notebook.

INTRODUCTION

You will recall from your study of BJT amplifiers that each transistor must be biased so that they will be operating in the active (linear) region. If this step is omitted, the output signal will be distorted. In this experiment, you will see how the selection of the bias network components directly affects the accuracy and stability of the bias point against component tolerances and transistor parameter variations. One of your designs will be used in Experiment #5.

PRELIMINARY

1. For the circuit in Figure 1, the transistor is biased so that I_{CQ} is 10 mA and V_{CEQ} is 8 V. As a starting point, let V_{RE} be 20% of V_{CC} . **Calculate the values needed for R_E and R_C .** Assume β is 100. Select the nearest standard values for the two resistors.

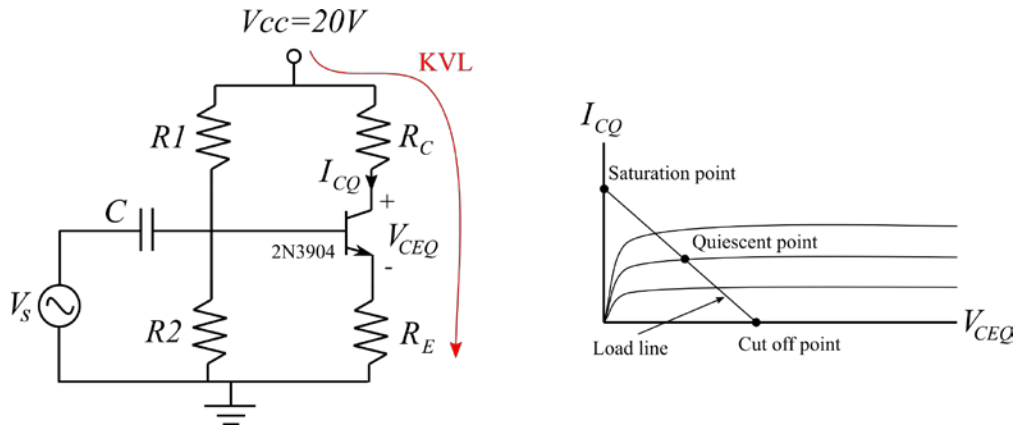

Figure 1: The basic biasing circuit for the BJT amplifier.

- Referring to Figure 2, set R_{th} to $\frac{(\beta+1)}{10} R_E$ and calculate the values of R_1 and R_2 . Select the nearest standard values. Recalculate the value of I_C . (This will be design #1, but also your bias design for Experiment #5.)

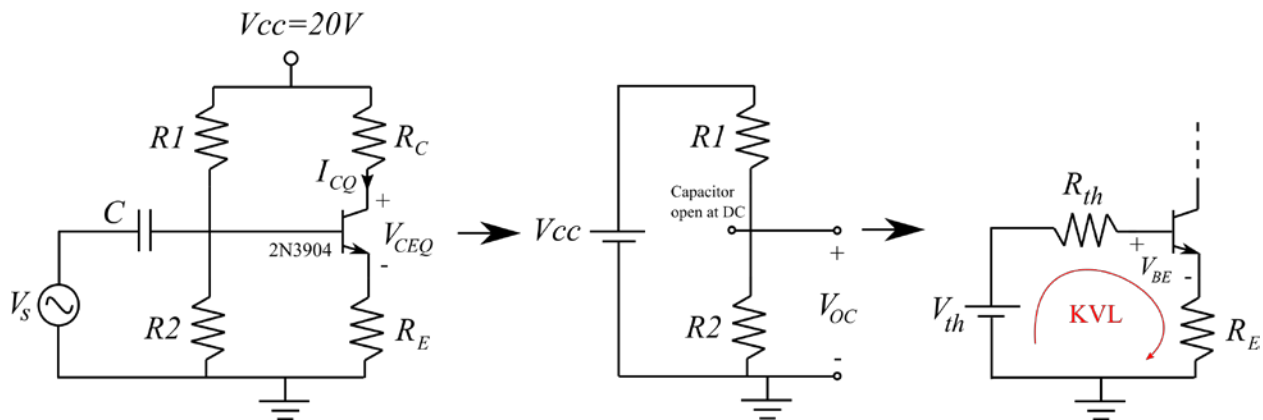

Figure 2: The equivalent circuit of the input bias circuit.

- Repeat the above procedure, except design for $V_{RE} = 40\% V_{CC}$. This will be design #2.

EXPERIMENT

- Select two or three 2N3904 transistors from the lab stock. You will use one at a time.
- Using a breadboard, construct design #1. After checking the connections, apply V_{CC} and measure the nodal voltages with respect to ground V_{CEQ} and V_{RE} . From the measured values calculate the value of the current I_C .
- Turn off the power and replace the transistor with the other one. Repeat the

measurements and calculation of Step 2. Note any differences.

- Now, construct the circuit again using the values calculated for Design #2. Repeat Steps 2 and 3.

Q1. What can you conclude about making R_E larger?

- Look over the results you have obtained and state any observations or conclusions you feel are important.

COMMENTARY

If the temperature of the circuit changes, the negative feedback provided by R_E will help stabilize the bias point against changes due to the temperature dependence of b , V_{BE} , and V_{CBO} . In special cases where I_C must be very stable against temperature changes, diode compensation may be used as shown in Figure 3. The idea is that as temperature increases, V_{BE} decreases, but so does the diode voltage V_D . If two diodes are used as in Figure 3(b), it is possible to almost completely compensate for temperature changes. The disadvantage of this technique, though, is that it decreases the input resistance of the amplifier. This is not a problem in some circuits such as constant current sources used in integrated circuits. Do you see why?

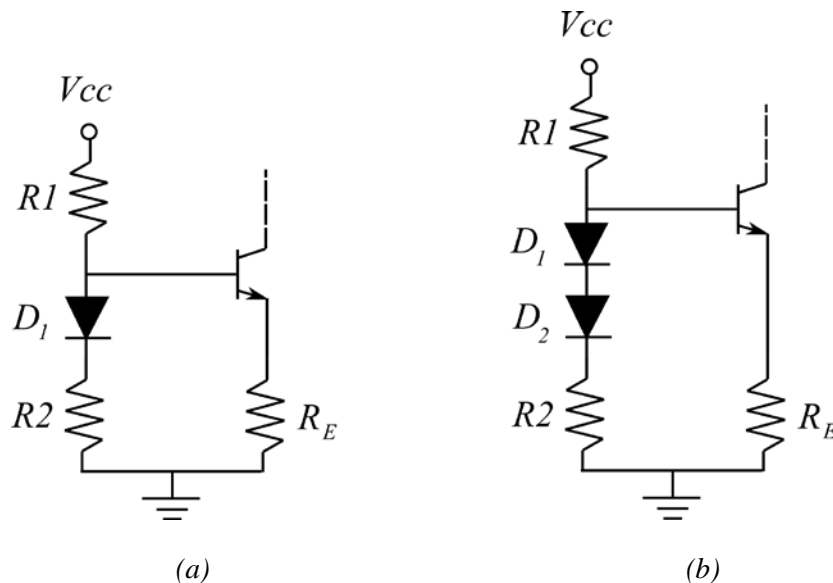

Figure 3: (a) Single-diode temperature compensation, (b) Two-diode compensation.