

## EXPERIMENT 2 ANALOG AND DIGITAL MULTIMETERS

### INTRODUCTION

Consider the two circuits shown in Figure 1 below.

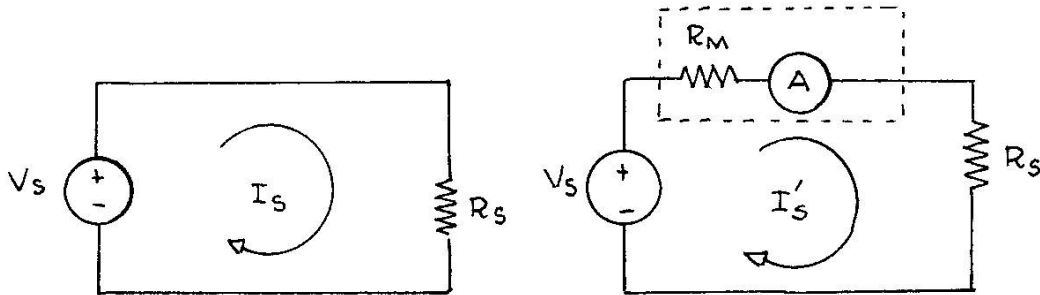

*Figure 1: Internal resistance of a nonideal ammeter*

The circuit on the left contains an ideal independent DC voltage source of  $V_s$  volts in series with an ideal resistance of  $R_s$  Ohms. The current  $I_s$  in the circuit would then have to be  $I_s = V_s / R_s$ . The circuit on the right has been modified to include an ammeter. An ammeter is an electromechanical transducer that converts electrical current into the mechanical rotation of a meter indicator. The degree of rotation is proportional to the current flowing through the ammeter. Ideally the ammeter measurement should correspond exactly to the calculated value of  $I_s$ . However, from a practical point of view there are many reasons why real ammeters fall short of this goal. One reason is that ammeters generally have some finite resistance (which we will call  $R_M$ ). Thus when the ammeter (shown as an ideal ammeter, A, in series with the internal resistance  $R_M$ ) is introduced into the circuit shown on the right side of Figure 1, it will not read  $I_s = V_s / R_s$ . Instead it will read  $I'_s = V_s / (R_s + R_M)$ . Of course if  $R_M \ll R_s$  the ammeter can still be considered to be a “pretty good” ammeter but perhaps not an ideal ammeter. There are other reasons why ammeters are less than ideal but many of these are beyond the scope of this experiment.

In this lab we will be working with multimeters rather than ammeters—specifically analog multimeters and digital multimeters. A basic analog multimeter consists of an ammeter combined with various electrical components to allow it to measure a wide range of currents as well as voltages and resistances. More advanced analog ammeters provide additional capabilities such as testing diodes and testing electrical continuity. Digital multimeters do not generally include an ammeter in the form of an electromechanical transducer but instead rely on digital electronic circuitry to provide a digital read out of voltages, currents and resistances. Nevertheless, there are some

common characteristics that apply to both analog and digital multimeters and these common characteristics will be explored in this experiment.

## OBJECTIVES

The purposes of this lab experiment are as follows:

1. Demonstrate a few methods for determining the internal resistance of an analog ammeter as well as a digital ammeter.
2. Understand how a shunt can be used to extend the range of an ammeter
3. Demonstrate how an analog ammeter can be used as a voltmeter.
4. Understand the Ohms per volt rating of an analog multimeter.

## EQUIPMENT

This experiment will use

1. A decade box of resistors (Elenco Model RS-500)
  2. An analog multimeter (Simpson Model 260)
  3. A digital multimeter (Tenma Model 72-410A)
  4. An oscilloscope (Agilent Model 54622A)
  5. A variable DC power supply (Tenma 72-6615)
- in addition to a breadboard, various small resistors, jumper cables, and alligators clips

## PROCEDURE

1. Connect your equipment to conform to the following diagram.

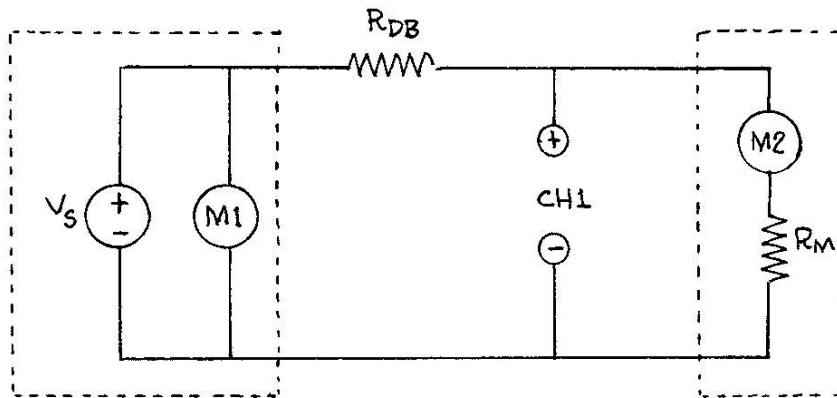

*Figure 2: Connections to measure the internal resistance of a multimeter*

In this diagram the parallel combination of  $V_s$  and  $M1$  represents the DC power supply.  $R_{DB}$  is the decade box.  $M2$  in series with  $R_M$  initially represents the analog multimeter (Simpson 260). Later in this experiment this series combination will be used to represent the digital multimeter. Note that in either case this multimeter is modeled as an ideal ammeter in series with some unknown resistance  $R_M$ . Finally  $CH1$  represents a cable going to channel 1 of the oscilloscope. Set the decade box at approximately  $10k\Omega$ , set the meter on the 1 mA scale, and turn the voltage knob on

the right side of your power supply fully counterclockwise. Once you have this circuit hooked up **DO NOT TURN THE POWER SUPPLY ON**. Instead ask your TA to check the circuit and to demonstrate how to measure the voltage on Channel 1 of the oscilloscope. Even though we have not yet discussed oscilloscopes in this course, the oscilloscope is probably the most accurate way available in this lab to make the measurements necessary to determine  $R_M$ .

2. Once the TA has checked your circuit and shown how to make the measurements you should turn on the power supply and adjust the voltage until  $M2$  reaches full scale, which in this case would be 1 mA. The value of  $M1$  should be roughly 10 volts and the value of  $CH1$  should be roughly one-quarter of a volt (or 250 mV). Record these values in your lab notebook. Adjust the voltage to reduce the value of  $M2$  to 0.8 and again record the values of  $M2$ ,  $M1$ , and  $CH1$ . Repeat these measurements and record the values of  $M2$ ,  $M1$ , and  $CH1$  for  $M2 = 0.6, 0.4$  and  $0.2$  mA. Hint: Prepare a three column by six row table in your lab notebook to enter this data—the first row can be used for labeling the columns.
3. Repeat the previous procedure, but this time set the meter on the 10 mA scale and set  $R_{DB}$  to be approximately  $1k\Omega$ . Also, this time instead of making measurements for  $M2 = 1, 0.8, 0.6, 0.4$ , and  $0.2$  mA please make your measurements for  $M2 = 10, 8, 6, 4, 2$  mA. Again, a six row by three column table provides a convenient way to record your data.
4. Replace the analog multimeter with the digital multimeter and repeat the procedures of steps 2 and 3. Be sure to record data for the digital multimeter in your lab notebook as well. Note the digital multimeter does not have a 1 mA and a 10 mA scale. Instead you will have to use 2 mA and 20 mA scales. Nevertheless, while making measurements on the 2 mA scale you should be using  $R_{DB} = 10k\Omega$  and should be making measurements at  $M2 = 1, 0.8, 0.6, 0.4$ , and  $0.2$  mA.. On the 20 mA scale you should be using  $R_{DB} = 1k\Omega$  and should be making measurements at  $M2 = 10, 8, 6, 4, 2$  mA.
5. To understand how shunts work, connect the following circuit (Figure 3).

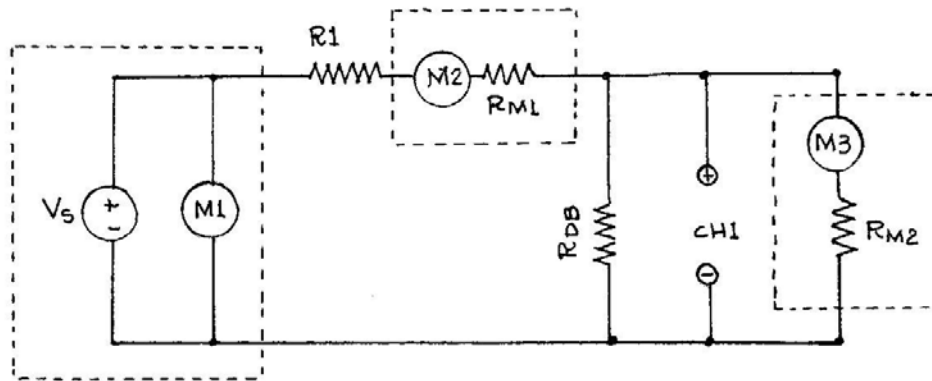

Figure 3: Using  $R_{DB}$  as a shunt

As before the parallel combination of  $V_s$  and  $M1$  represents the variable voltage DC supply. The series combination of  $M2$  and  $R_{M1}$  represents the digital multimeter while the series combination of  $M3$  and  $R_{M2}$  represents the analog multimeter. Resistor  $R1$  is a  $10k\Omega$  composition resistor from the parts box in the lab. It is in the circuit only to provide a current limiter in case someone uses the wrong settings on the analog multimeter. The decade resistor box is shown as  $R_{DB}$  and this is the shunt resistor. Suppose that for some reason the analog multimeter only works on the 1 mA scale. This means that the maximum amount of current that can be read by the analog multimeter is 1 mA. If the current flowing through the meter exceeds 1 mA by a small amount, the indicator on the meter will be “pegged” at the maximum value of 1 mA and will therefore not provide a reliable reading. If the current through the meter exceeds 1 mA by a large amount the meter itself may be damaged. Take our word for it.....please don't try it!

Now suppose we know the value of  $R_{M2}$  and suppose we know that the current through the digital multimeter is going to be somewhere between 0 and 2 mA. If we want to extend the range of the analog multimeter so that it can read a current of 2 mA without going offscale we can, in theory, set the value of  $R_{DB}$  exactly equal to the value of  $R_{M2}$ . In this case a current of 2 mA flowing through  $M2$  will split evenly between the branch containing  $R_{DB}$  and the branch containing the analog multimeter. Thus the 2 mA current through  $M2$  will result in a current of 1 mA flowing through the analog multimeter. In this case the current flowing through  $M2$  will be equal to the analog multimeter reading multiplied by a factor of 2. The shunt resistance of the decade box has thereby allowed us to extend the range of the analog multimeter so that a full scale reading now corresponds to a current of 2 mA.

The circuit shown in Figure 3 can also be used to determine the internal resistance  $R_{M2}$ . Therefore, construct this circuit, set the analog multimeter on the 1 mA scale

and set  $R_{DB}$  at approximately  $400\ \Omega$ . Record five sets of values for  $M3$  (mA),  $M1$  (V),  $M2$  (mA), and  $CH1$  (V) by adjusting the DC supply voltage so that  $M3 = 1, 0.8, 0.6, 0.4,$  and  $0.2$  mA.

- The analog multimeter can also be used to measure voltages.

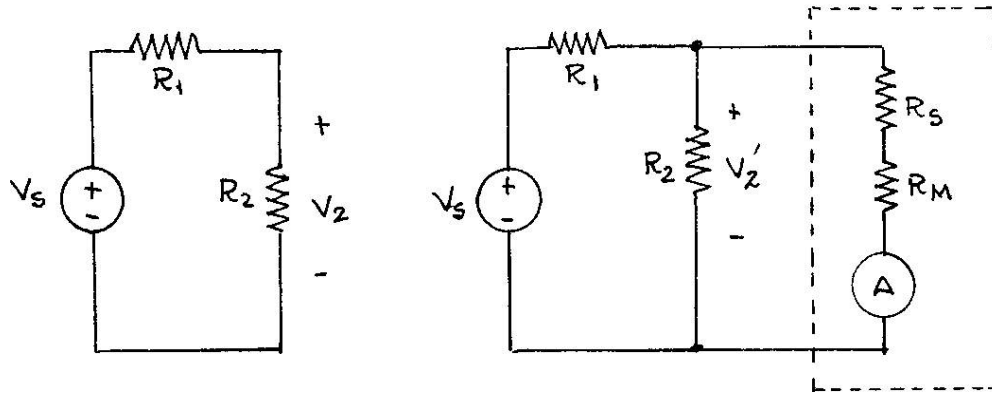

Figure 4: Analog multimeter used to measure voltage

The circuit on the left side of Figure 4 shows a simple resistive voltage divider. The voltage across  $R_2$  is simply given by

$$V_2 = V_s \frac{R_2}{R_1 + R_2}$$

The circuit on the right shows the analog multimeter connected in parallel with resistor  $R_2$ . The current flowing through the ammeter will be

$$I = \frac{V'_2}{R_s + R_M}$$

so that there is a simple linear relationship between the voltage  $V'_2$  and the current  $I$  flowing through the meter, namely

$$V'_2 = IR'_M$$

where  $R'_M = R_s + R_M$ . Ideally the voltage  $V'_2$  would be exactly equal to the voltage  $V_2$ . Realistically, the voltage  $V'_2$  will differ from the voltage  $V_2$  in which case the multimeter is said to “load” the circuit being measured. In other words the quantity we are trying to measure ( $V_2$ ) is being changed by the process of making the measurement! In order to identify the cause of this loading, consider the ratio  $V'_2/V_2$ .

If the multimeter does not load the circuit at all, the ratio will be equal to 1. Otherwise

$$V_2' = V_s \frac{\left( \frac{R_2 R_M'}{R_2 + R_M'} \right)}{R_1 + \left( \frac{R_2 R_M'}{R_2 + R_M'} \right)}$$

where  $\left( \frac{R_2 R_M'}{R_2 + R_M'} \right)$  is the resistance of  $R_2$  and  $R_M'$  in parallel and as previously noted

$$V_2 = V_s \frac{R_2}{R_1 + R_2}$$

Therefore, the ratio will generally be given by the following somewhat complicated expression

$$\frac{V_2'}{V_2} = \frac{\left( \frac{R_2 R_M'}{R_2 + R_M'} \right) \frac{R_1 + R_2}{R_2}}{R_1 + \left( \frac{R_2 R_M'}{R_2 + R_M'} \right)}$$

Nevertheless, by choosing to make the value of  $R_s$  sufficiently large it is possible to cause  $R_M' \gg R_2$  in which case the previous complicated expression for the voltage ratio reduces to

$$\frac{V_2'}{V_2} = \frac{\left( \frac{R_2 R_M'}{R_2 + R_M'} \right) \frac{R_1 + R_2}{R_2}}{R_1 + \left( \frac{R_2 R_M'}{R_2 + R_M'} \right)} \approx \frac{\left( \frac{R_2 R_M'}{R_M'} \right) \frac{R_1 + R_2}{R_2}}{R_1 + \left( \frac{R_2 R_M'}{R_M'} \right)} = \frac{R_2}{R_1 + R_2} \frac{R_1 + R_2}{R_2} = 1$$

The following circuit shows how to determine (approximately) the value of  $R_M'$  for the analog multimeter when it is used to measure voltage.

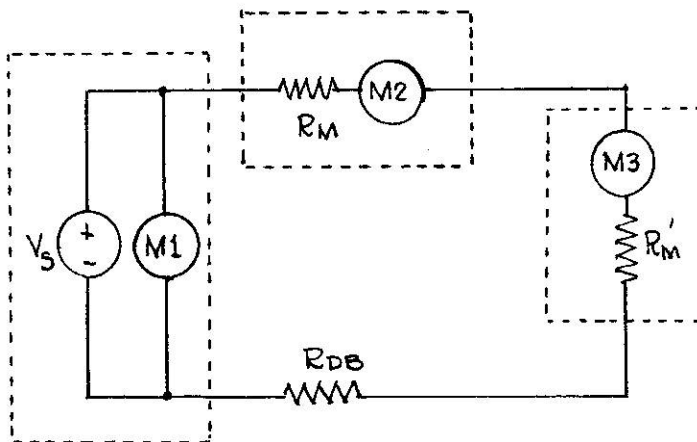

Figure 5: Measurement configuration for determining the value of  $R_M'$

Connect this circuit where  $R_{DB}$  is approximately  $1000\Omega$ . The box containing  $M2$  and the resistor  $R_M$  represents the digital multimeter set on the 2 mA scale. The box

containing  $M3$  and the unknown resistance  $R'_M$  represents the analog multimeter set on the 2.5 Volt scale. Again the purpose of the decade box resistance is to act as a current limiter. By adjusting the DC voltage, the values of  $M3$  can be set to 2.5, 2.0, 1.5, 1.0, and 0.5 Volts. For each such value of  $M3$  record the corresponding values of  $M1$  (Volts) and  $M2$  (mA).

7. Set the voltmeter on the 10 Volt scale. By adjusting the DC voltage, the values of  $M3$  can be set to 10, 8, 6, 4, and 2 Volts. For each such value of  $M3$  record the corresponding values of  $M1$  (Volts) and  $M2$  (mA).

### ANALYSIS

1. Consider the data obtained in procedure step 2. Using the values of  $CH1$  and  $M2$ , the value of  $R_M$  can be calculated quite simply as

$$R_M = \frac{CH1}{M2} \text{ [method 1]}$$

where the value of  $M2$  is in units of Amperes and the value of  $CH1$  is in units of Volts. There is another way to calculate the value of  $R_M$  without using the oscilloscope measurement. In this case calculation is based on the measurements of  $M1$  and  $M2$  and the presumably known value of  $R_{DB}$ . In this case

$$R_M = \frac{M1}{M2} - R_{DB} \text{ [method 2]}$$

For each one of the five values of  $M2$  calculate the value of  $R_M$  using both methods 1 and 2.

2. Repeat these calculations for the data obtained in procedure step 3.
3. Repeat these calculations for the data obtained in procedure step 4 for the 2 mA scale
4. Repeat these calculations for the data obtained in procedure step 4 for the 20 mA scale.
5. Suppose that you have an ammeter with an internal impedance of 100 Ohms and a full scale reading of 50 microamperes. By adding a shunt resistor, it is claimed that the range of the ammeter can be extended to 10 mA. Calculate the value of shunt resistance needed to make the full scale reading on the ammeter corresponding to 10 mA.
6. Develop a formula for calculating the internal ammeter resistance ( $R_{M2}$ ) based on the measurements of  $M2$ ,  $CH1$ , and  $M3$  in procedure step 5. Use this formula to calculate the value of  $R_{M2}$  for each of the five measurements made in this procedure step.
7. The value of  $R'_M$  in procedure steps 6 and 7 can be calculated approximately from

$$R'_M = \frac{M3}{M2}$$

Calculate the value of  $R'_M$  for each of the five measurements made in procedure step 6 (2.5 volt scale) and procedure step 7 (10 volt scale). If you look carefully at the

face of the analog multimeter you will see a specification of a specific number of Ohms per volt for DC measurements. How is this specification related to the values of  $R'_M$  you have calculated?

### CONCLUSIONS:

Some possible questions to consider in your conclusions include:

- Which of the two procedures (methods 1 and 2) in analysis step 1 are more accurate and why?
- Suppose that you had a choice between an ideal ammeter (internal resistance of  $0\Omega$ ) with a full scale reading of 1 mA and a nonideal ammeter (internal resistance of  $1\Omega$ ) with a full scale reading of 1 mA. Describe a possible application in which the nonideal ammeter might be better suited than the ideal ammeter.
- The simple formula given for analysis step 7 is described as an approximation. What assumptions provide the basis of this approximation?
- Is there a logical relationship between the value of  $R_M$  when the analog meter is used on the 1 mA scale and the value of  $R_M$  when the analog meter is used on the 10 mA scale?